

Compact Coarse Wavelength Division Multiplexer (CCWDM)

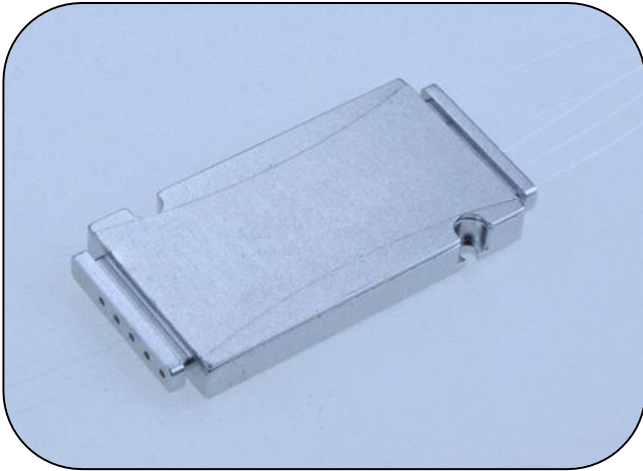

Features

- Low Insertion Loss
- High Isolation
- Low PDL
- Compact Design
- Good channel-to-channel uniformity
- Wide Operating Wavelength:
1260 nm ~ 1620 nm
- Wide Operating Temperature:
-40°C ~ 85°C
- High Reliability and Stability

Applications:

- CWDM System
- PON Networks
- CATV Links

Compliance

- Telcordia GR-1209-CORE-2001
- Telcordia GR-1221-CORE-1999
- RoHS

Specifications

CWDM Mux/Demux Module (Technical Grade)

Parameters		1x4 (+UPG)	1x8 (+UPG)
Center Wavelength (nm)		ITU, ITU+1	
Passband (nm)		ITU±6.5	
Operating Wavelength (nm)		1460~1620 or 1260~1620	
Channel Space (nm)		20	
Fiber Type		SMF-28e (0.9 mm Loose Tube)	
Insertion Loss(dB)		≤1.2	≤1.8
COM→UPG Port		≤1.4	≤2.0
Isolation (dB)	Adjacent Channel	≥30	
	Non-Adjacent Channel	≥40	
Ripple (dB)		≤0.3	
PDL (dB)		≤0.2	
PMD (ps)		≤0.1	
RL (dB)		≥45	
Directivity (dB)		≥50	
Maximum Optical Power (mw)		500	
Fiber length (m)		1.0 or customized	
Operating Temperature (°C)		-40~85	
Storage Temperature (°C)		-40~85	
Box Package (mm) (LxWxH)		45*25*6	

Notes:

- 1) All specifications are based on the devices without connectors, and guaranteed over wavelength, polarization and temperature.
- 2) PMD and chromatic dispersion values are guaranteed by design.
- 3) IL is 0.2dB higher, RL is 5dB lower for each connector added.

Mechanical Dimensions

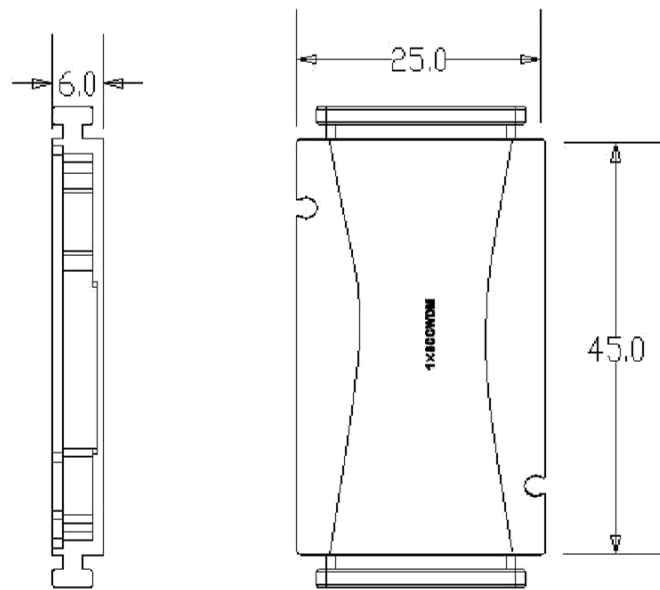

Inter-connect Diagram:

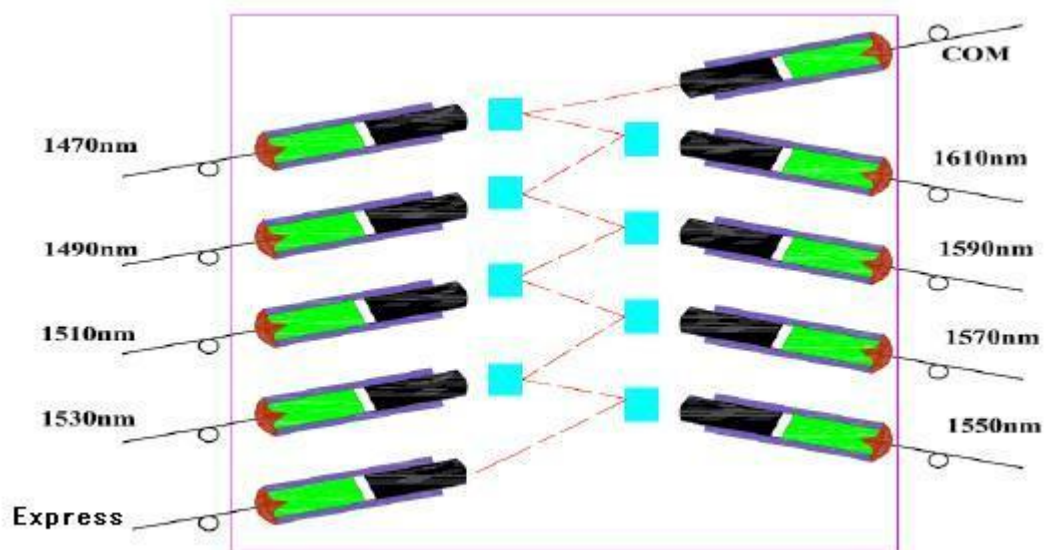

Mux/Demux Configuration (Typ. for 8-Ch)

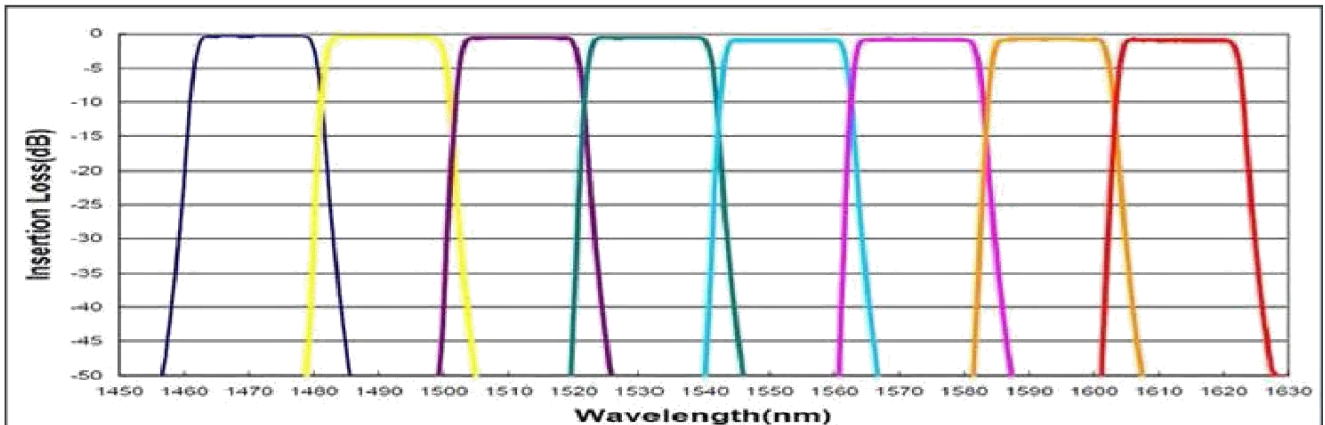

Ordering information¹

PN	Description
XMcc-dCffgS	Compact CWDM, small package, temperature range -40~+85 Channel number: cc = {02 – 1x2, 04 – 1x4, 08 – 1x8} Module type: d = {M – MUX single fiber, type A, N - MUX single fiber, type B} Start wavelength: ff = {27 – 1270 nm, 29 – 1290 nm, 31 – 1310 nm, 33 – 1330 nm, 35 – 1350 nm, 37 – 1370 nm, 39 – 1390 nm, 41 – 1410 nm, 43 – 1430 nm, 45 – 1450 nm, 47 – 1470 nm, 49 – 1490 nm, 51 – 1510 nm, 53 – 1530 nm, 55 – 1550 nm, 57 – 1570 nm, 59 – 1590 nm, 61 – 1610 nm} Connector type: g = {O – none, L – LC, M – LC/APC, S – SC, T – SC/APC, X - customized}

Notes:

¹ For accurate order specification please contact Xenopt reseller before placing an order. The content of this document is subject to change without notice. Xenopt does not guarantee errorless or outdated information.

Important Notice

Performance figures, data and any illustrative material provided in this data sheet are typical and must be specifically confirmed in writing by XenOpt before they become applicable to any particular order or contract. In accordance with the XenOpt policy of continuous improvement specifications may change without notice.

The publication of information in this data sheet does not imply freedom from patent or other protective rights of XenOpt or others. Further details are available from any XenOpt sales representative.

To find out more, please contact: