

## XSB3WL-20xx

155M~1.25Gbps SFP Bi-Directional  
Transceiver, 20 km Reach  
1310 nm TX/1490~1550 nm RX

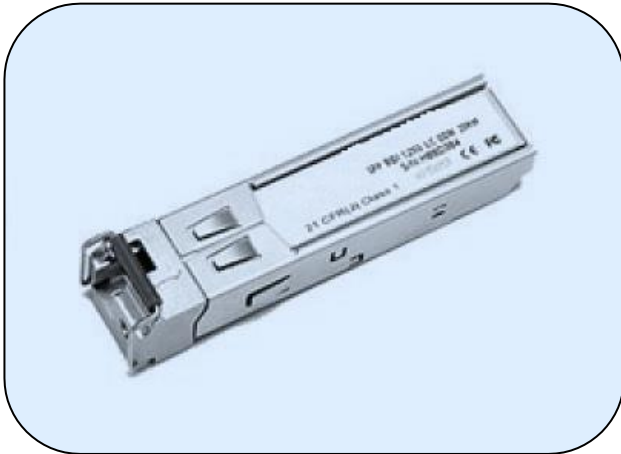

### Features

- Multi-rate of 155M~1.25Gbps operation
- 1310 nm FP laser and PIN photodetector for 20 km transmission
- Wide receiving wavelength range 1490 nm to 1550 nm
- Compliant with SFP MSA and SFF-8472 with simplex LC or SC receptacle
- Digital Diagnostic Monitoring: Internal Calibration or External Calibration
- Compatible with SONET OC-24-LR-1
- +3.3V single power supply
- RoHS6 compliant
- Operating case temperature:  
0°C to 70 °C (Commercial)  
-40°C to 85°C (Industrial)

### Applications

- Gigabit Ethernet
- Fiber Channel
- Switch to Switch interface
- Switched backplane applications
- Router/Server interface
- Other optical transmission systems

### Description

The SFP-BIDI transceivers are high performance, cost effective modules supporting dual data-rate of 1.25Gbps/1.0625Gbps and 20km transmission distance with SMF.

The transceiver consists of three sections: a FP laser transmitter, a PIN photodiode integrated with a trans-impedance preamplifier (TIA) and MCU control unit. All modules satisfy class I laser safety requirements.

The transceivers are compatible with SFP Multi-Source Agreement (MSA) and SFF-8472. For further information, please refer to SFP MSA.

Module Block Diagram

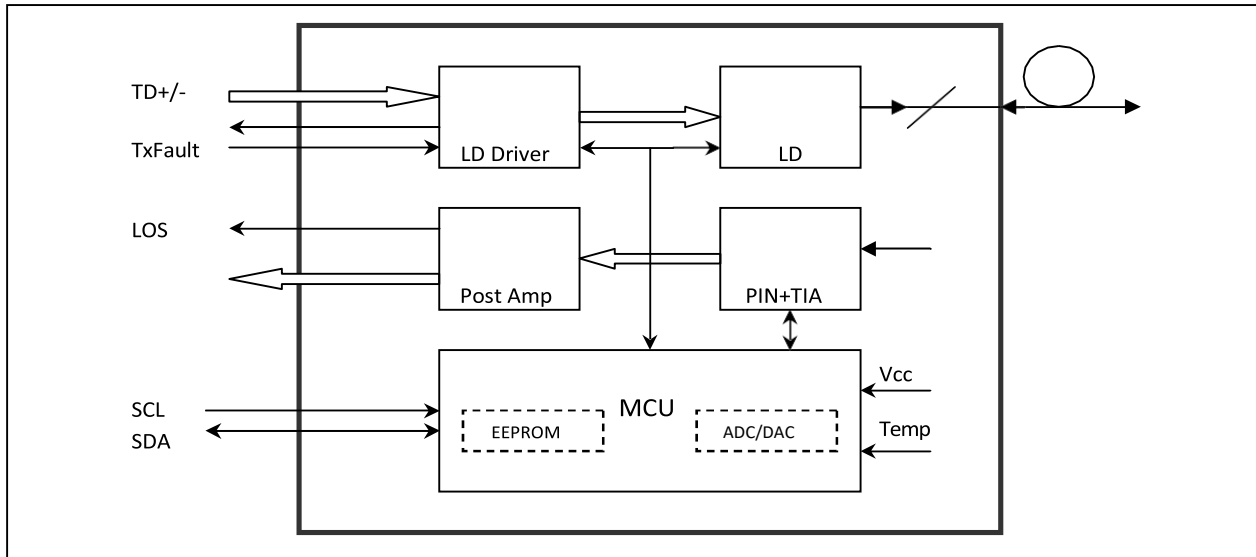

Absolute maximum rating

Parameters	Symbol	Min.	Max.	Unit
Supply Voltage	V <sub>cc</sub>	-0.5	4.5	V
Storage Temperature	T <sub>s</sub>	-40	+85	°C
Operating Humidity	-	5	85	%

Recommended Operating Conditions

Parameter		Symbol	Min	Typical	Max	Unit
Operating Case Temperature	Commercial	T <sub>c</sub>	0		+70	°C
	Industrial		-40		+85	°C
Power Supply Voltage		V <sub>cc</sub>	3.13	3.3	3.47	V
Power Supply Current		I <sub>cc</sub>			300	mA
Data Rate			155		1250	Mbps

### Optical and Electrical characteristics

Parameter	Symbol	Min	Typical	Max	Unit	Notes
<b>Transmitter</b>						
Centre Wavelength	$\lambda_c$	1260	1310	1360	nm	
Spectral Width (RMS)	$\sigma$			4	nm	
Average Output Power	P <sub>out</sub>	-9		0	dBm	1
Extinction Ratio	ER	9			dB	
Optical Rise/Fall Time (20%~80%)	t <sub>r</sub> /t <sub>f</sub>			0.26	ns	
Data Input Swing Differential	V <sub>IN</sub>	400		1800	mV	2
Input Differential Impedance	Z <sub>IN</sub>	90	100	110	$\Omega$	
TX Disable	Disable		2.0		V <sub>cc</sub>	V
	Enable		0		0.8	V
TX Fault	Fault		2.0		V <sub>cc</sub>	V
	Normal		0		0.8	V
<b>Receiver</b>						
Centre Wavelength	$\lambda_c$	1480		1580	nm	
Receiver Sensitivity				-23	dBm	3
Receiver Overload		-3			dBm	3
LOS De-Assert	LOSD			-24	dBm	
LOS Assert	LOSA	-35			dBm	
LOS Hysteresis		1		4	dB	
Data Output Swing Differential	V <sub>out</sub>	400		1800	mV	4
LOS	High	2.0		V <sub>cc</sub>	V	
	Low			0.8	V	

#### Notes

1. The optical power is launched into SMF.
2. PECL input, internally AC-coupled and terminated.
3. Measured with a PRBS 2<sup>7</sup>-1 test pattern @1250Mbps, BER ≤ 1×10<sup>-12</sup>.
4. Internally AC-coupled.

### Ordering information<sup>1</sup>

Part number	Product Description
XSB3WL-20SN	1310 nm, 155 M~1.25 Gbps, SC, 20 km, 0°C~+70°C
XSB3WL-20SY	1310 nm, 155 M~1.25 Gbps, SC, 20 km, 0°C~+70°C, DDM
XSB3WL-20SL	1310 nm, 155 M~1.25 Gbps, SC, 20 km, -40°C~+85°C
XSB3WL-20SM	1310 nm, 155 M~1.25 Gbps, SC, 20 km, -40°C~+85°C, DDM
XSB3WL-20LN	1310 nm, 155 M~1.25 Gbps, LC, 20 km, 0°C~+70°C
XSB3WL-20LY	1310 nm, 155 M~1.25 Gbps, LC, 20 km, 0°C~+70°C, DDM
XSB3WL-20LL	1310 nm, 155 M~1.25 Gbps, LC, 20 km, -40°C~+85°C
XSB3WL-20LM	1310 nm, 155 M~1.25 Gbps, LC, 20 km, -40°C~+85°C, DDM

#### Notes

<sup>1</sup> For accurate order specification please contact XenOpt reseller before placing an order. The content of this document is subject to change without notice. XenOpt does not guarantee errorless or outdated information.

Please specify any compatibility requirements at time of ordering. Standard MSA compatible pluggable components may not work or some function of these components may not be available in devices that require customized compatible devices. Pluggable components compatible with one type of communications equipment may not work in other type of communications equipment.

#### Important Notice

Performance figures, data and any illustrative material provided in this data sheet are typical and must be specifically confirmed in writing by XenOpt before they become applicable to any particular order or contract. In accordance with the XenOpt policy of continuous improvement specifications may change without notice.

The publication of information in this data sheet does not imply freedom from patent or other protective rights of XenOpt or others. Further details are available from any XenOpt sales representative.

To find out more, please contact: