

XTDxxB-40LY

16 G FC 100 GHz DWDM 40 km Digital Diagnostic
SFP+ LC Single-mode Transceiver



Applications

- Multi-rate 16x/8x/4x Fibre Channel
- 10G FCoE

Description

The XTDXXB-40LY series single mode transceiver is a small form factor pluggable module for bi-directional serial optical data communications such as 16x/8x/4x Fibre Channel. It is with the SFP+ 20-pin connector to allow hot plug capability. Digital diagnostic functions are available via an I²C. This module is designed for single mode fiber and operates at a nominal wavelength of 100GHz ITU Grid, C Band DWDM wavelength. A guaranteed minimum optical link budget of 14 dB is offered. The transmitter section uses temperature-stabilized DWDM electrical- modulated laser (EML) and is a class 1 laser compliant according to International Safety Standard IEC-60825. The receiver section uses an integrated InGaAs detector preamplifier (IDP) mounted in an optical header and a rate selection clock data recovery (CDR) IC.

Laser safety

This single mode transceiver is a Class 1 laser product. It complies with IEC-60825 and FDA 21 CFR 1040.10 and 1040.11. The transceiver must be operated within the specified temperature and voltage limits. The optical ports of the module shall be terminated with an optical connector or with a dust plug.

Features

- Up to 14.025 Gbps Bi-directional Data Links
- Complaint to SFP+ MSA
- Compliance with Fibre Channel 1600-SM-LC-L
- Maximum Link Length of 40 km
- Temperature-stabilized DWDM EML Transmitter
- 14 dB Power Budget at Least
- 100 GHz ITU Grid, C Band
- RX Rate Selection for 16G FC and 8G/4G FC
- Flexibility in RX data rate selection through either hardware or software control
- SFF-8472 Digital Diagnostic Function
- AC/AC Coupling according to MSA
- Single +3.3 V Power Supply
- RoHS 6/6 Compliant
- 0 to 70°C Operating
- Class 1 Laser International Safety Standard IEC-60825 Compliant

Absolute Maximum Ratings

Parameter	Symbol	Min	Max	Units	Notes
Storage Temperature	Tstg	-40	85	°C	
Relative Humidity	RH	5	85	%	Non-condensing
Operating Case Temperature	Topr	0	70	°C	
Power Supply Voltage	Vcc	-0.5	3.6	V	
Receiver Input Optical Power	Mip		3	dBm	Average power

Recommended Operating Conditions

Parameter	Symbol	Min	Typ	Max	Units/Notes
Power Supply Voltage	Vcc	3.135	3.3	3.465	V
Operating Case Temperature	Topr	0		70	°C
Relative Humidity	RH	5		85	% / Non-condensing
Power Supply Current	ICC (TX+RX)		350	550	mA
Data Rate		4.25	14.025		Gb/s

Transmitter Optical Specifications (0°C < Topr < 70°C, 3.13V < Vcc < 3.47V)

Parameter	Symbol	Min	Typ	Max	Units	Notes
Average Launch Power	P _{O,AVG}	0		4	dBm	1
Extinction Ratio	ER	8.2			dB	
Center Wavelength Spacing			100		GHz	2
Transmitter Center Wavelength -- over life time	c	X-100	X	X+100	pm	3
Output Spectrum Width		---		1	nm	-20 dB width
Side Mode Suppression Ratio	SMSR	30			dB	
Transmitter and Dispersion Penalty @ 800 ps/nm	TDP			2	dB	
Relative Intensity Noise	RIN			-130	dB/Hz	
Average Launch Power of OFF Transmitter				-30	dBm	

Notes

- Output power is power coupled into a 9/125 m single-mode fiber.
- Corresponds to approximately 0.8 nm.
- X = specified ITU Grid wavelength.

Receiver Optical Specifications (0°C < Topr < 70°C, 3.13V < Vcc < 3.47V)

Parameter	Symbol	Min	Typ	Max	Units	Notes
Sensitivity				-14	dBm	4
Receiver Overload	P _{MAX}	1	---		dBm	
LOS – Deasserted	LOS _D	---	---	-14	dBm	Transition: low to high
LOS – Asserted	LOS _A	-24	---	---	dBm	Transition: high to low
Wavelength of Operation	c	1480		1580	nm	
Optical Return Loss	ORL			-27	dB	

Notes

4. Measured with worst ER; BER < 10⁻¹² and PRBS 2³¹-1. Equivalent to -14.3 dBm OMA at ER=8.2 dB.

Electrical Characteristics

Parameter	Symbol	Min	Typ	Max	Units	Notes
High-Speed Signal (CML) Interface Specification						
Input Data Rate		4.25	14.025		Gb/s	
TX Clock Tolerance		-100		+100	ppm	5
Differential Input Impedance	R _{in}		100		Ω	
Differential Data Input Amplitude		150		1200	mVpp	Internally AC coupled
Output Data Rate		4.25	14.025		Gb/s	
RX Clock Tolerance		-100		+100	ppm	5
Differential Output Impedance	R _{out}		100		Ω	
Differential Data Output Amplitude		350	600	700	mVpp	Internally AC coupled
Low-Speed Signal (LVTTTL) Interface Specification						
Input High Voltage		2.0		V _{cc} +0.3	V	
Input Low Voltage		GND		0.8	V	
Output High Voltage		2.4		V _{cc}	V	
Output Low Voltage		GND		0.5	V	

Notes

5. Clock tolerance for 14.025 Gb/s, 8.5Gb/s and 4.25 Gb/s.

Connection Diagram

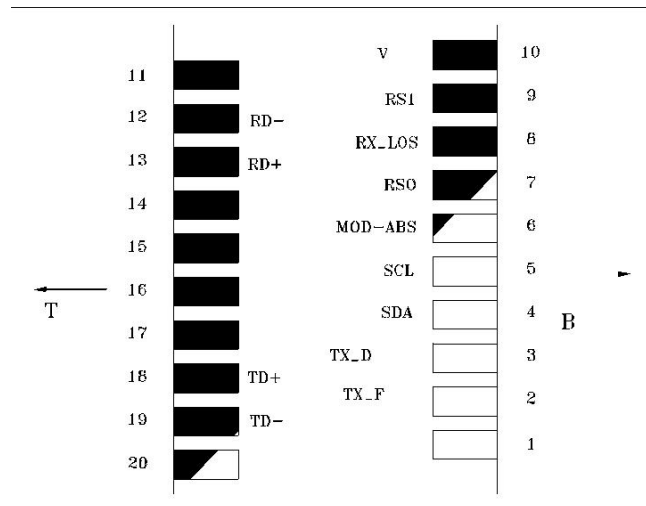

PIN	Signal Name	Description	PIN	Signal Name	Description
1	V _{EE} T	Transmitter Signal Ground	11	V _{EE} R	Receiver Signal Ground
2	TX_Fault	Transmitter Fault Indication. Logic "1" Output = Laser Fault. Logic "0" Output = Normal Operation	12	RD-	Inverse Receiver Data Out
3	TX_Disable	Logic "1" Input (or no connection) = Laser off, Logic "0" = Laser on.	13	RD+	Receiver Data Out
4	SDA	Modulation Definition 2 - Two wires serial ID Interface	14	V _{EE} R	Receiver Signal Ground
5	SDL	Modulation Definition 1 - Two wires serial ID Interface	15	V _{CC} R	Receiver Power - 3.3V±5%
6	MOD-ABS	Modulation Definition 0 - Ground in Module	16	V _{CC} T	Transmitter Power - 3.3V±5%
7	RS0	RX Rate Select: Open or Low: 8.5 or 4.25 Gb/s FC. High: enable CDR for 16GFC.	17	V _{EE} T	Transmitter Signal Ground
8	RX_LOS	Loss of Signal Out (OC).	18	TD+	Transmitter Data In
9	RS1	TX Rate Select (LVTTL). This pin has an internal 30k pulldown to ground. A signal on this pin will not affect module performance.	19	TD-	Inverse Transmitter Data In
10	V _{EE} R	Receiver Signal Ground	20	V _{EE} T	Transmitter Signal Ground

Module Definition

Module Definition	PIN 4	PIN 5	PIN 6	Interpretation by Host
4	SDA	SCL	MOD-ABS	Serial module definition protocol

Module Definition 4 specifies a serial definition protocol. For this definition, upon power up, SDA and SCL appear as no connector (NC) and MOD-ABS is TTL LOW. When the host system detects this condition, it activates the serial protocol. The protocol uses the 2-wire serial CMOS E²PROM protocol of the ATMEL AT24C01A/02/04 family of components.

RX Rate Select Control

RX rate can be independently controlled by either RS0 input pin (Hardware) or via register write to soft RS0 select bit (Software). RS0 input pin (pin 7) is used to select RX rate. Status of RS0 input pin logic level is reflected to register byte 110 bit 4 on address A2h. RX rate can also be controlled by register write to soft RS0 select bit (byte 110 bit 3 on address A2h). Power on default of soft RS0 select bit is logic low. Hardware and software control inputs are OR'd to allow flexible control. See following RX operation logic table:

RS0 Control Input		RX Speed	RX CDR
RS0 Input Pin (Hardware: Pin 7)	Soft RS0 Select Bit (Software: Byte 110 Bit 3, A2h)		
0	0	4G/8G FC	Bypassed
0	1	16G FC	Enabled
1	0		
1	1		

Recommended circuit schematic

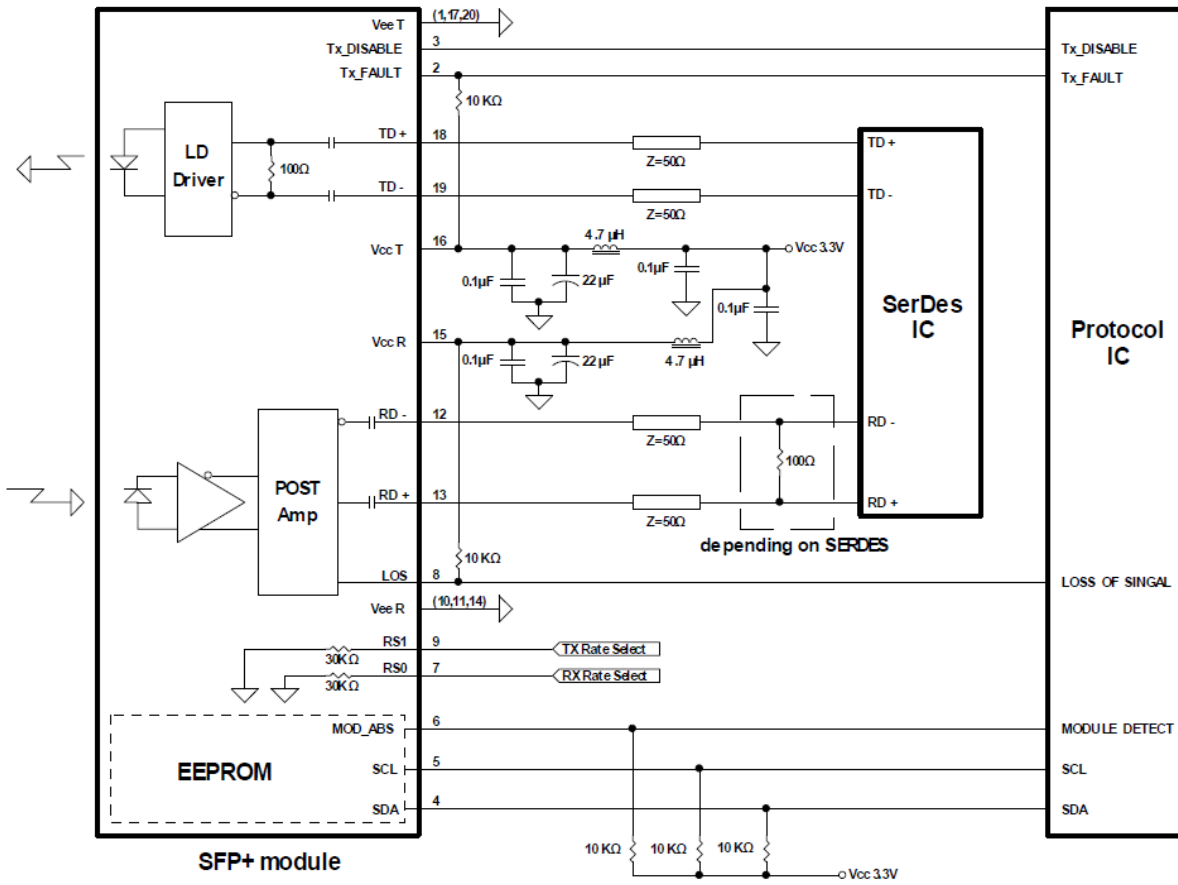

Package Diagram

Units in mm

Top View

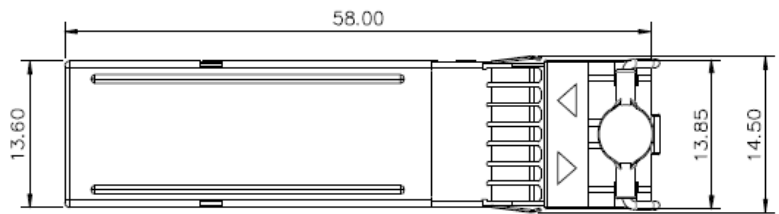

Front View

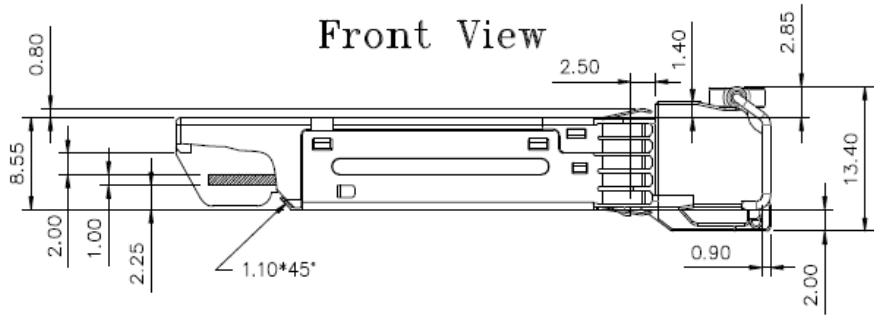

LATCH COLOR
Red

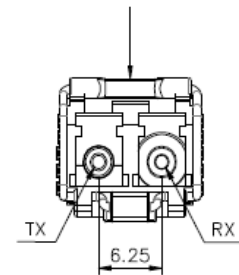

Side View

Bottom View

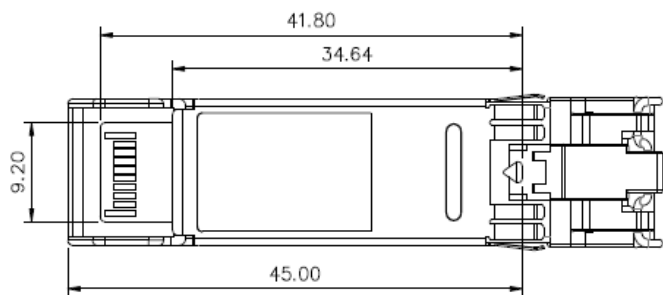

Note: Specifications subject to change without notice.

EEPROM Series ID Memory Contents (Address A0h)

Addr	Hex	ASCII	Note	Addr	Hex	ASCII	Note	Addr.	Hex	ASCII	Note	Addr	Hex	ASCII	Note
0	03		SFP+	32	20			64	06		Cooled Tx,	96	00		Vendor specific EEPROM
1	04			33	20			65	3A		Power Level 2, Txdis, Txfault, LOS enable, RX Rate Select	97	00		
2	07		LC	34	20			66	00		Up bit rate	98	00		
3	80		10G Base-ER	35	20			67	00		Low bit rate	99	00		
4	00			36	00		NA	68			Serial number: each piece with different serial number	100	00		
5	00			37	00		Vendor IEEE OUI	69				101	00		
6	00			38	0E			70				102	00		
7	10		Long Distance (L)	39	FA			71				103	00		
8	10		Longwave Laser (LL)	40	53	S	Part Number	72				104	00		
9	01		Single Mode (SM)	41	50	P		73				105	00		
10	F0		1600/1200/800/400 Mbytes/sec	42	53	S		74				106	00		
11	06		64B/66B	43	2D	-		75				107	00		
12	8C		14.025Gbps	44	36	6		76				108	00		
13	08		Rx Rate_select only, High=16G, Low=10G/8G/4G	45	33	3		77				109	00		
14	28		40km	46	34	4		78				110	00		
15	FF		>25.4km	47	31	1		79				111	00		
16	00			48	57	W		80				112	00		
17	00			49	2D	-		81				113	00		
18	00			50	44	D		82				114	00		
19	00			51	3x	X		83				115	00		
20	4F	O	Vendor name	52	3x	X		84			Date Code	116	00		
21	50	P		53	47	G		85				117	00		
22	54	T		54	20			86				118	00		
23	4F	O		55	20			87				119	00		
24	57	W		56	30	0	Revision, depended on version	88				120	00		
25	41	A		57	30	0		89					121	00	
26	59	Y		58	30	0		90					122	00	
27	20		59	31	1		91				123	00			
28	20		60			DWDM Wavelength	92	68		Monitoring	124	00			
29	20		61				93	FA		Soft Control and Monitoring	125	00			
30	20		62				94	05		SFF-8472V11.0	126	00			
31	20		63			Checksum 0-62	95			Checksum 64-94	127	00			

EEPROM Series ID Memory Contents (Address A2h)

Addr	Hex	Note	Addr.	Hex	Note	Addr.	Hex	Note	Addr	Hex	Note
0	4B	Temp. High Alarm (75°C)	32	3D	Rx Power High Alarm (2dBm)	64	00	For External Cal.	96		Real Time Temp. MSB
1	00		33	E9		65	00		For External Cal.	97	
2	FB	Temp. Low Alarm(-5°C)	34	00	Rx Power Low Alarm (-16dBm)	66	00	For External Cal.	98		Real Time Vcc MSB
3	00		35	FB		67	00		For External Cal.	99	
4	49	Temp. High Warming(73°C)	36	31	Rx Power High Warming (1dBm)	68	3F	For External Cal.	100		Real Time Tx Bias MSB
5	00		37	2D		69	80		For External Cal.	101	
6	00	Temp. Low Warming (0°C)	38	01	Rx Power Low Warming(-14dBm)	70	00	For External Cal.	102		Real Time Tx Pwr MSB
7	00		39	8E		71	00		For External Cal.	103	
8	8C	Voltage High Alarm (3.6V)	40	3C	LD Temp. High Alarm (60°C)	72	00	For External Cal.	104		Real Time Rx Pwr MSB
9	A0		41	00		73	00		For External Cal.	105	
10	75	Voltage Low Alarm(3.0V)	42	19	LD Temp. Low Alarm(25°C)	74	00	For External Cal.	106		Reserved
11	30		43	00		75	00		For External Cal.	107	
12	88	Voltage High Warming(3.5V)	44	37	LD Temp. High Warming(55°C)	76	01	For External Cal.	108		Reserved
13	B8		45	00		77	00		For External Cal.	109	
14	79	voltage Low Warming (3.1V)	46	1E	LD Temp. Low Warming (30°C)	78	00	For External Cal.	110		Tx Dis, RS(0), Tx Fault, Rx Los
15	18		47	00		79	00		For External Cal.	111	
16	FD	Tx Bias High Alarm(130mA)	48	27	ITEC High Alarm(1000mA)	80	01	For External Cal.	112		Alarm Flag
17	E8		49	10		81	00		For External Cal.	113	
18	13	Tx BiasLow Alarm(10mA)	50	D8	ITEC Low Alarm(-1000mA)	82	00	For External Cal.	114		Reserved
19	88		51	F0		83	00		For External Cal.	115	
20	EA	Tx Bias High Warming(120mA)	52	27	ITEC High Warming(1000mA)	84	01	For External Cal.	116		Warming Flag
21	60		53	10		85	00		For External Cal.	117	
22	1D	Tx Bias Low Warming(15mA)	54	D8	ITEC Low Warming(-1000mA)	86	00	For External Cal.	118		Reserved
23	4C		55	F0		87	00		For External Cal.	119	
24	7B	Tx Power High Alarm (5dBm))	56	00	For External Cal.	88	01	For External Cal.	120		Vendor Specific
25	87		57	00		For External Cal.	89		00	For External Cal.	
26	1F	Tx Power Low Alarm(-1dBm)	58	00	For External Cal.	90	00	For External Cal.	122		
27	07		59	00		For External Cal.	91		00	For External Cal.	
28	62	Tx Power High Warming(4dBm)	60	00	For External Cal.	92	00	For External Cal.	124		
29	1F		61	00		For External Cal.	93		00	For External Cal.	
30	27	Tx Power Low Warming (0dBm)	62	00	For External Cal.	94	00	For External Cal.	126		
31	10		63	00		For External Cal.	95			Check Sum	

Note: Address 128 – 247: customer R/W EEPROM. Address 248 – 255: Vendor Specific.

Note: Specifications subject to change without notice.

Ordering information¹

PN	Description
XTDxxB-40LY	xx= ITU Grid 19~61, 16 Gbps, DWDM SFP+ 40km, DDM, -0°C ~ +70°C

Notes:

¹ For accurate order specification please contact Xenopt reseller before placing an order. The content of this document is subject to change without notice. Xenopt does not guarantee errorless or outdated information.

Important Notice

Performance figures, data and any illustrative material provided in this data sheet are typical and must be specifically confirmed in writing by XenOpt before they become applicable to any particular order or contract. In accordance with the XenOpt policy of continuous improvement specifications may change without notice.

The publication of information in this data sheet does not imply freedom from patent or other protective rights of XenOpt or others. Further details are available from any XenOpt sales representative.

To find out more, please contact: