

X86-OLP – Optical Protection Card



APPLICATIONS

- Optical line 1+1 protection (OLP)
- Optical multiplexing section 1+1 protection (OMSP)
- Optical channel 1+1 Protection (OCHP)

DESCRIPTION

The primary function of the Optical Protection Card (OLP) is to enhance Wavelength Division Multiplexing (WDM) systems by providing comprehensive optical layer protection solutions, including Optical Line 1+1 Protection and Optical Wavelength 1+1 Protection, among others. This card monitors the optical signal status of both the primary and standby routes in real time. In the event of an interruption or degradation in signal quality, it automatically switches to the backup route, ensuring rapid recovery of the optical signal and maintaining system integrity.

OLP technology facilitates route switching operations at the optical layer, offering significant advantages over protection mechanisms at higher layers. This makes it the optimal solution for delivering non-blocking communication to users.

FEATURES

- Real-Time Monitoring: Continuously tracks the optical signal status of both main and standby routes
- Automatic Switching: Instantly switches to the standby route in case of signal interruption or degradation, ensuring minimal downtime
- Optical Layer Operation: Performs route switching directly at the optical layer, providing faster response times compared to higher-layer solutions.
- Non-Blocking Communication: Maintains uninterrupted data transmission, allowing for seamless communication without bottlenecks
- Multiple protection schemes, including:
 - Optical Line 1+1 Protection (OLP)
 - Optical Multiplexing Section 1+1 Protection (OMSP)
 - Optical Channel 1+1 Protection (OCHP)
- Enhanced Reliability, User-Friendly Interface, Scalability

FUNCTIONAL DIAGRAM

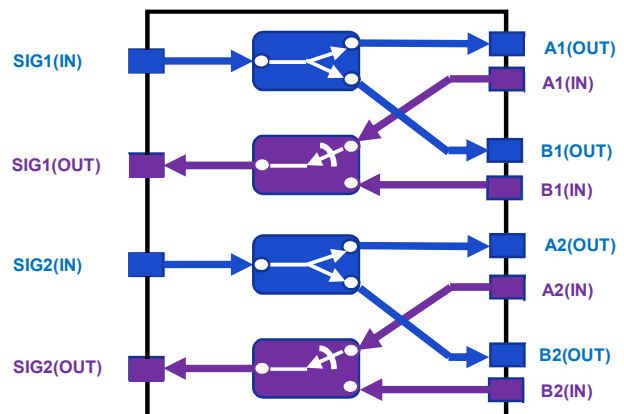

PRODUCT SPECIFICATION

| Parameter | Note |
|----------------------------------|---|
| Function | Support optical signal 1+1 protection, double transmitting and selective receiving, single terminal switching |
| Slot number | 1 slot |
| Integration | Support 1 or 2 groups of optical protection modules (optional according to the application scenario) |
| Working wavelength range | 1528 nm ~ 1568 nm |
| Insertion loss | TX≤4 dB, RX≤1.5 dB |
| Switching time | <5 ms (switching time of pure optical switch) |
| Input optical power | -25 dBm ~ +21 dBm |
| Optical power detection accuracy | ±0.5 dBm (@>-25 dBm or above) |
| Polarization dependent loss | ≤0.1 dB |
| Isolation degree | >50 dB |
| Return loss | >45 dB |
| Switching time | > (10) ⁷ |
| Switching condition | Relative power difference and absolute power value |
| Switching method | Support locking, forced switching, manual switching and automatic switching |
| Reliability | Power down/power on latch, hot pluggable, and main controller card (SCU) failure does not affect protection switching |

ORDERING INFORMATION

| Part number | Product Description |
|-------------|--------------------------------------|
| X86-OLP | XenOpt X8600 Optical Protection Card |

Notes

For accurate order specification please contact XenOpt reseller before placing an order. The content of this document is subject to change without notice. XenOpt does not guarantee errorless or outdated information.

COMPANY INFORMATION

XENYA d.o.o.
Celovška cesta 172
1000 Ljubljana, SI

CONTACT INFORMATION

info@xenya.si
+386 (0)1 514 06 10
www.xenopt.com

PARTNER INFORMATION

Important notice

Performance figures, data and any illustrative material provided in this data sheet are contains typical values and must be specifically confirmed in writing by XenOpt before they become applicable to any particular order or contract. Specifications may change without notice.
The publication of information in this data sheet does not imply freedom from of patent or other protective rights of XenOpt or others. Further details are available from any XenOpt sales representative.

XenOpt™ is a trademark owned by Xenya d.o.o.