

X86-OLP2

Optical protection card, two-way OLP 1+1 protection, occupied 1 slot



FEATURES

- Supports optical layer 1+1 protection schemes (OLP, OMSP, OCHP)
- Enables automatic switching between primary and backup optical paths
- Provides real-time monitoring of optical signal status
- Ensures fast fault detection and rapid service recovery
- Performs protection switching at the optical layer (faster than higher-layer protection)
- Improves network reliability and service continuity
- Helps maintain uninterrupted communication

APPLICATIONS

Supports optical line 1+1 protection (OLP), optical multiplex section 1+1 protection (OMSP), and optical channel 1+1 protection (OCHP).

DESCRIPTION

The Optical Line Protection (OLP) board enables optical-layer protection in WDM systems, supporting schemes such as optical line 1+1 and wavelength 1+1 protection. It continuously monitors the signal quality of both primary and backup paths and automatically switches between them in the event of signal loss or degradation, ensuring rapid service recovery. By performing protection switching at the optical layer, OLP provides faster response and greater reliability compared to higher-layer protection, helping maintain uninterrupted communications.

FUNCTIONAL STRUCTURE

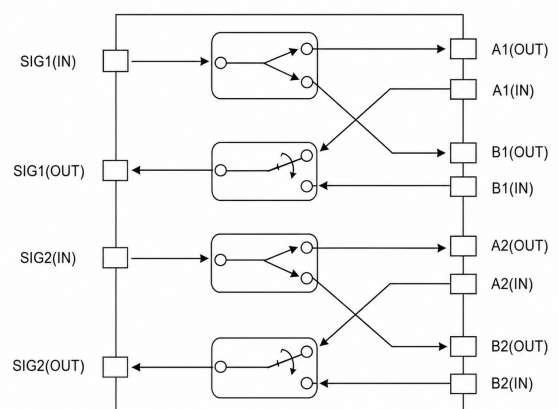

Parameter	Specification
Function	1+1 optical signal protection, dual-transmit selective reception, single-end switching
Slot	1 slot
Integration	Supports 1 or 2 groups of optical protection modules (optional)
Working wavelength range	1528–1568 nm
Insertion loss	≤4 dB (transmit), ≤1.5 dB (receive)
Switching time	<5 ms (pure optical switching)
Input optical power	-25 dBm to +21 dBm
Optical power detection accuracy	±0.5 dBm (≥ -25 dBm)
Polarization dependent loss	≤0.1 dB
Isolation	>50 dB

ORDERING INFORMATION

Part number	Specification
X86-OLP2	Optical protection card, two-way OLP 1+1 protection, occupied 1 slot

Notes

For accurate order specification please contact XenOpt reseller before placing an order. The content of this document is subject to change without notice. XenOpt does not guarantee errorless or outdated information.

COMPANY INFORMATION

XENYA d.o.o.
 Celovška cesta 1720
 1000 Ljubljana, SI

CONTACT INFORMATION

info@xenya.si
 +386 (0)1 514 06 10
www.xenopt.com

PARTNER INFORMATION

Important notice

Performance figures, data and any illustrative material provided in this data sheet are contains typical values and must be specifically confirmed in writing by XenOpt before they become applicable to any particular order or contract. Specifications may change without notice.

The publication of information in this data sheet does not imply freedom from of patent or other protective rights of XenOpt or others. Further details are available from any XenOpt sales representative.