

## XDB431-20Lx

1.25 Gbps BIDI CSFP Transceiver, DDM, 20 km

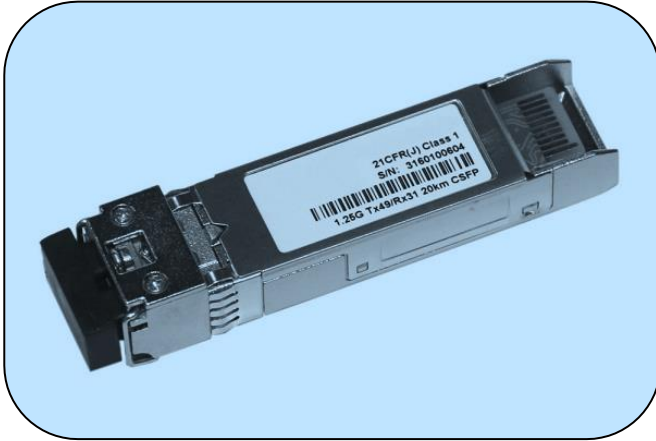

### Applications

- 1000BASE BX IEEE802.3ah
- Point to Point FTTH
- Switched Backplane Applications
- Router/Server Interface
- Switch to Switch Interface
- Other Optical Links

### Description

XDB431-20Lx CSFP transceivers, according to Compact Small Form Factor Pluggable Multi-Sourcing Agreement (MSA) option 2, The transceiver consists of 2-channel Bi-directional Optical Transceiver unit with five sections: the LD driver, the limiting amplifier, the digital diagnostic monitor, the 1490 nm DFB laser and the PIN photo-detector. The module data link up to 20 km in 9/125 um single mode fiber.

XDB431-20Lx CSFP transceivers offer a wide range of design options, including Digital Diagnostic Monitoring (DDM) features and three temperature options (commercial, extended or industrial).

XDB431-20Lx CSFP are compliant with RoHS.

### Features

- Compliant with IEEE Std 802.3-2005, 1000BASE-BX-D
- Compliant with SFF-8074i and SFF-8472, revision 9.5
- Compliant with SFP MSA Specification
- Digital Diagnostic Monitoring available
- Uncooled 1490 nm DFB Laser
- Up to 1.25 Gbps bi-directional data links
- Up to 20 km on 9/125 μm SMF
- Simplex LC connector compliant
- Single +3.3 V DC power supply
- Hot-pluggable CSFP footprint
- Class 1 laser safety certified
- Operating temperature Options
  - (Commercial) -10°C to +70°C
  - (Extended) -10°C to +85°C
  - (Industrial) -40°C to +85°C
- RoHS6 Compliant
- Compliant to reliability requirements of Telcordia GR-468-CORE

## Pin Description

Pin	Name	Function/Description	Notes
1	VEE	Transceiver Ground	VEE may be internally connected within the SFP module
2	TX Fault	Transmitter Fault Indication	TX Fault is an open collector/ drain output, which should be pulled up with a 4.7K–10K resistor on the host board. Note 1 for more information
3	TX1_Disable	Transmitter Disable of Ch A	Module channel A disables function
4	MOD-DEF2	Two-wires interface Data	2 wire serial ID interface, SDA
5	MOD-DEF1	Two-wires interface Clock	2 wire serial ID interface, SCL
6	TD2-	Inverted Transmit Data Input of Ch B	These are the differential transmitter puts. They are AC-coupled, differential lines with 100 differential termination inside the module. The AC coupling is done inside the module and is thus not required on the host board
7	TD2+	Transmit Data Input of Ch B	
8	LOS1	Loss of Signal of Ch A	Loss of Signal detected function. Note 2 for more information.
9	RD2+	Received Data Output of Ch B	These are the differential receiver outputs. They are AC coupled 100 differential lines which should be terminated with 100(differential) at the user SERDES. The AC coupling is done inside the module and is thus not required on the host board.
10	RD2-	Inverted Received Data Output of Ch B	
11	VEE	Transceiver Ground	VEE may be internally connected within the SFP module.
12	RD1-	Inverted Received Data Output of Ch A	These are the differential receiver outputs. They are AC coupled 100 differential lines which should be terminated with 100(differential) at the user SERDES. The AC coupling is done inside the module and is thus not required on the host board.
13	RD1+	Received Data Output of Ch A	
14	LOS2	Loss of Signal of CH B	Loss of Signal detected function. Note 2 for more information.
15	VCCR	Receiver Power	3.3V± 5%. Note 3 for more information
16	VCCT	Transmitter Power	3.3V± 5%. Note 3 for more information
17	TX2_Disable	Transmitter Disable of Ch B	Module channel B disables function
18	TD1+	Transmit Data Input of Ch A	These are the differential transmitter puts. They are AC-coupled, differential lines with 100 differential termination inside the module. The AC coupling is done inside the module and is thus not required on the host board
19	TD1-	Inverted Transmit Data Input of Ch A	
20	VEE	Transceiver Ground	VEE may be internally connected within the SFP module.

## Notes

1. When high, output indicates a laser fault of some kind either in Channel A or Channel B. The Host shall read Channel A/B for details: TX Fault from channel A if bit 2 is set in [A2H:110]; TX Fault from channel B if bit 2 is set in [B2H: 110]. Low indicates normal operation. In the low state, the output will be pulled to < 0.8V.
2. When high, this output indicates the received optical power is below the worst-case receiver sensitivity (as defined by the standard in use). Low indicates normal operation. In the low state, the output will be pulled to < 0.4V.
3. VccT VccR are the power supplies. They are defined as 3.3V  $\pm$ 5% at the SFP connector pin. Maximum supply current is 400Ma@3.3V. Vcc may be internally connected within the SFP transceiver module.

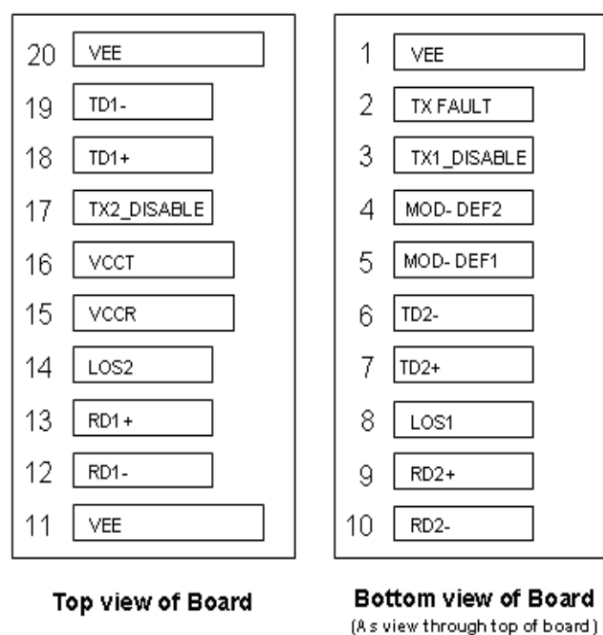
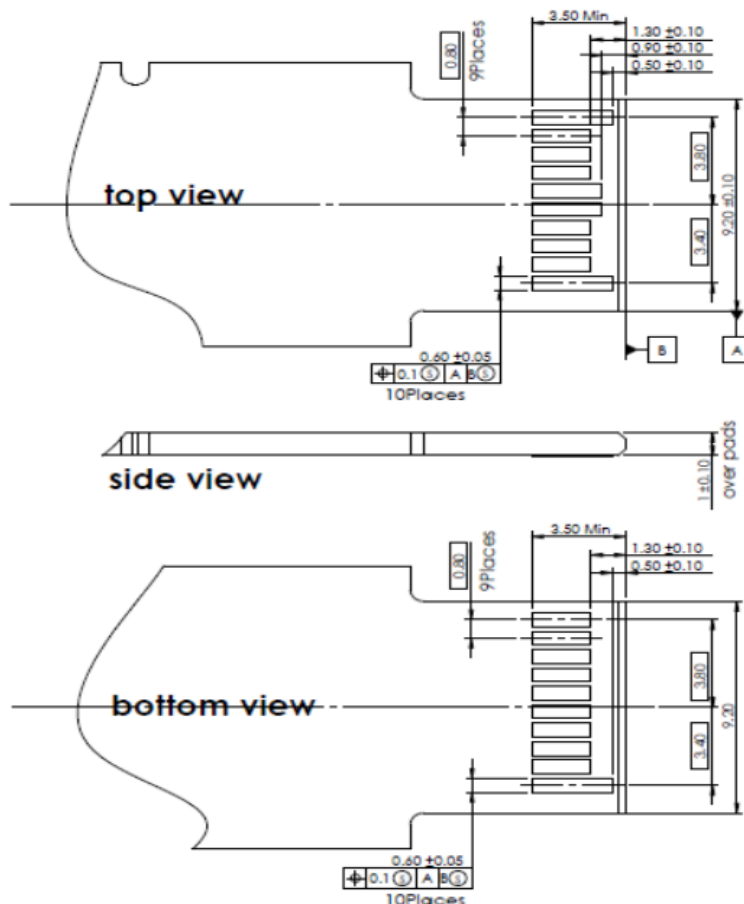

Figure 1. Pin out of Connector Block on Host Board



### Absolute Maximum Ratings

Stresses in excess of the absolute maximum ratings can cause permanent damage to the device. These are absolute stress ratings only. Functional operation of the device is not implied at these or any other conditions in excess of those given in the operational sections of the data sheet. Exposure to absolute maximum ratings for extended periods can adversely affect device reliability.

Parameter	Symbol	Minimum	Maximum	Unit
Storage Temperature	$T_s$	-40	85	°C
Relative Humidity	RH	5	95	%
Supply Voltage	$V_{CC}$	-0.5	4	V

## Recommended Operating Conditions

Parameter		Symbol	Min	Typ	Max	Unit
Operating Case Temperature	XDB431-20LY	T <sub>c</sub>	-10	-	70	°C
	XDB431-20LE	T <sub>e</sub>	-10		85	°C
	XDB431-20LM	T <sub>i</sub>	-40		85	°C
Supply Voltage		V <sub>CC</sub>	3.15	3.3	3.45	V
Data Rate		-	-	1.25/1.25	-	Gb/s

## Transceiver Electrical Characteristics

Parameter	Symbol	Min	Typ	Max	Unit	Notes
Module Supply Current	I <sub>CC</sub>	-	-	450	mA	-
Power dissipation	P <sub>D</sub>	-	-	1.5	W	-
Low speed output: Transmitter Fault(TX_FAULT) / Loss of Signal (LOS)	VOH	2.0	-	V <sub>CC</sub> +0.3	V	1
	VOL	0	-	0.8	V	-
Low speed iutput: Transmitter Disable (TX_DISABLE), MOD_DEF 1, MOD_DEF 2	VIH	2.0	-	V <sub>CC</sub> +0.3	V	2
	VIL	0	-	0.8	V	-

### Notes

1. Pulled up externally with a 4.7 KΩ-10 KΩ resistor on the host board to V<sub>CCT,R</sub>.
2. Mod\_Def1 and Mod\_Def2 must be pulled up externally with a 4.7 KΩ-10 KΩ resistor on the host board to V<sub>CCT,R</sub>.

### Transmitter Optical Characteristics

Parameter	Symbol	Minimum	Typical	Maximum	Unit	Notes
Launch Optical Power	P <sub>o</sub>	-9	-	-3	dBm	-
Center Wavelength Range	λ <sub>c</sub>	1470	1490	1510	nm	-
Extinction Ratio	EX	9	-	-	dB	-
Spectral Width (-20dB) @1490nm	Δλ	-	-	1	nm	-
Pout @TX-Disable Asserted	P <sub>off</sub>	-	-	-45	dBm	-
Eye Diagram	Compliant with IEEE802.3 ah (class 1 laser safety)					

### Receiver Optical Characteristics

Parameter	Symbol	Minimum	Typical	Maximum	Unit	Notes
Wavelength Range	-	1260	1310	1360	nm	-
Receiver Sensitivity	S	-	-	-20	dBm	1
Receiver Overload	P <sub>OL</sub>	-3	-	-	dBm	1
Optical Return Loss	ORL	12	-	-	dB	-
LOS De-Assert	LOS <sub>D</sub>	-	-	-22	dBm	1
LOS Assert	LOS <sub>A</sub>	-35	-	-	dBm	-
LOS Hysteresis	-	0.5	3	5	dB	-

#### Notes

1. Measured with PRBS 2<sup>7</sup>-1 test pattern, 1.25 Gb/s, EX=9 dB, BER<10<sup>-12</sup>.

## Digital Diagnostic Memory Map

### Channel 1:

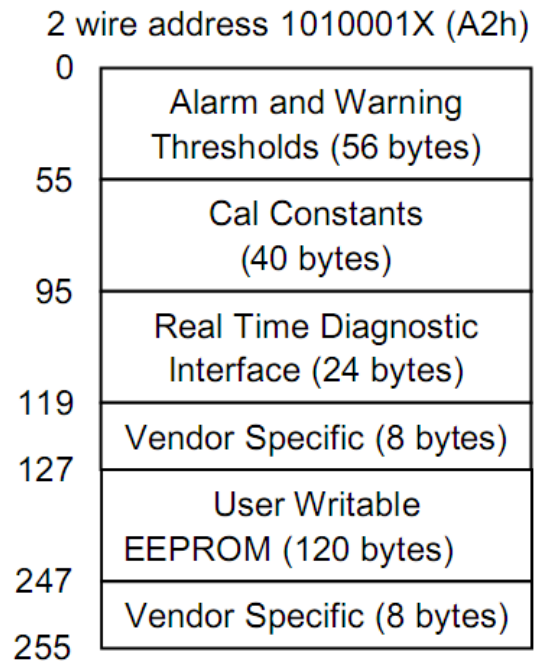
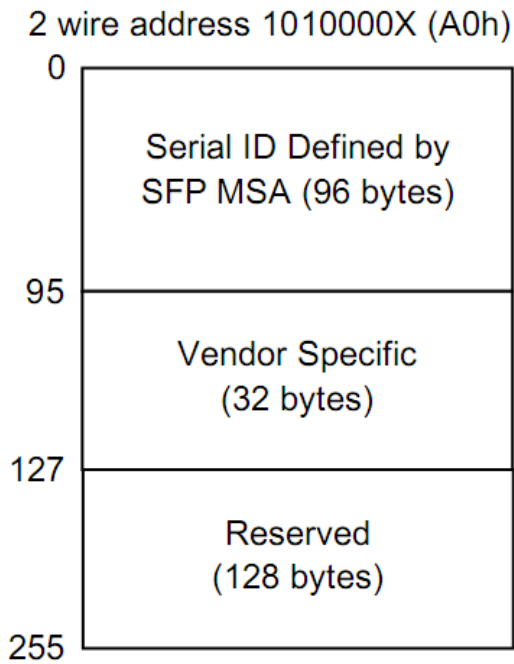

### Channel 2:

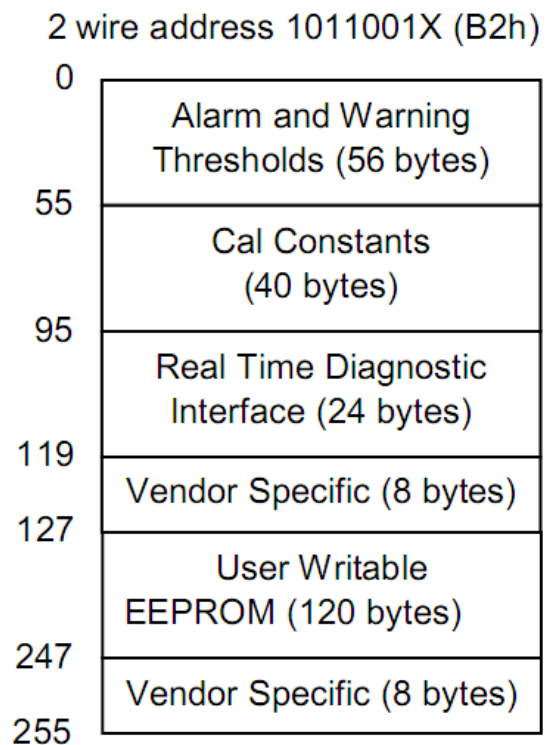
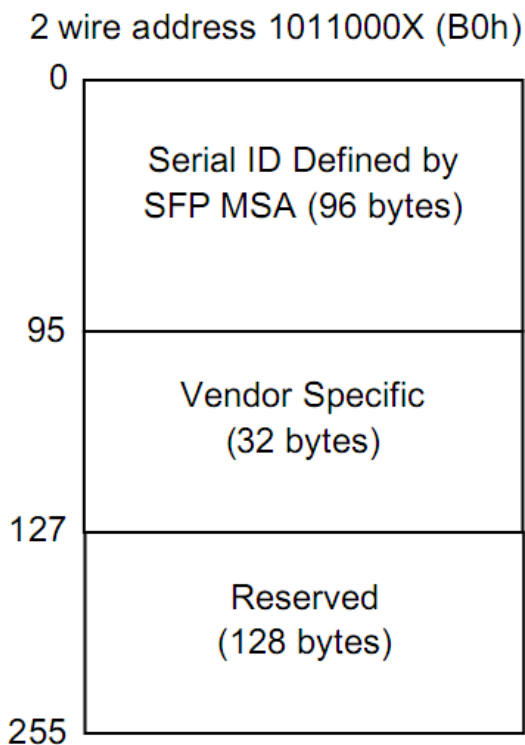

Figure 2. Digital Diagnostic Memory Map Specific Data Field Descriptions

## EEPROM Serial ID Memory Contents

The CSFP MSA defines a 256-byte memory map in E2PROM that is accessible over a 2-wire serial interface at the 8 bit address 1010000X (A0h) or 1011000X(B0h). The digital diagnostic monitoring interface makes use of the 8 bit address 1010001X (A2h) or 1011001X(B2h), so the originally defined serial ID memory map remains unchanged.

Table. Data Fields for 2ch Compact SFP

Data Address	Name of Field	Contents (Hex)	Description
0	Identifier	03	SFP
1	Ext. Identifier	04	SFP function is defined by serial ID
2	Connector	07	LC
3-10	Transceiver	00 00 00 40 12 00 01 01	1000BASE-BX-D
11	Encoding	01	8B/10B
12	BR, Nominal	0C	1.25 Gb/s
13	Reserved	00	-
14	Length (9 μm) km	14	20 km
15	Length (9 μm) 100 m	28	20000 m
16	Length (50 μm) 10 m	00	-
17	Length (62.5 μm) 10 m	00	-
18	Length (Copper)	00	-
19	Reserved	00	-
20-35	Vendor name	4C 49 4E 4B 54 45 4C 20 20 20 20 20 20 20 20 20	"XENOPT"(ASCII)
36	Reserved	00	
37-39	Vendor OUI	00 00 00	
40-55	Vendor PN	4C 58 32 35 30 32 xx 44 52 20 20 20 20 20 20 20	"XDB431-20Lx " (ASCII)
56-59	Vendor rev	31 2E 30 00	Rev 1.0 ( ASCII)
60-61	Wavelength	05 D2	1490 nm
62	Reserved	00	
63	CC BASE	xx	Check sum of bytes 0 - 62
64-65	Options	00 12	LOS, TX_DISABLE
66	BR, max	00	
67	BR, min	00	
68-81	Vendor SN	31 34 30 30 30 38 32 32 20 20 20 20 20 20	Serial Number of transceiver (ASCII). For example "14000822".
82		2D	2Dh, ASCII code of "-"



83		32	Channel number in ASCII code(31h for ch1 and 32h for ch2)
84-91	Vendor date code	xx xx xx xx xx xx 20 20	Year (2 bytes), Month (2 bytes), Day (2 bytes)
92	Diagnostic type	68	Diagnostics (Internally Cal)
93	Enhanced option	90	Diagnostics(Optional Alarm/warning flags, Soft TX_LOS monitoring)
94	SFF-8472	02	Diagnostics(SFF-8472 Rev 9.5)
95	CC_EXT	xx	Check sum for bytes 64-94
96-255		00	

Note: The “xx” byte should be filled in according to practical case. For more information, please refer to the related document of SFF-8472 Rev 9.3.

### Diagnostic Monitor Specifications

The operating and diagnostics information is monitored and reported by a Digital Diagnostics Transceiver Controller (DDTC) inside the transceiver, which is accessed through a 2-wire serial interface. When the serial protocol is activated, the serial clock signal (SCL, Mod Def 1) is generated by the host. The positive edge clocks data into the SFP transceiver into those segments of the E2PROM that are not write-protected. The negative edge clocks data from the SFP transceiver. The serial data signal (SDA, Mod Def 2) is bi-directional for serial data transfer. The host uses SDA in conjunction with SCL to mark the start and end of serial protocol activation. The memories are organized as a series of 8-bit data words that can be addressed individually or sequentially.

Parameter		Range	Accuracy	Calibration
Temperature	XDB431-20LY	-15 to +80°C	±3°C	Internal
	XDB431-20LE	-15 to +95°C	±3°C	Internal
	XDB431-20LM	-40 to +95°C	±3°C	Internal
Voltage		2.9 to 3.6V	±3%	Internal
Bias Current		0 to 80mA	±10%	Internal
TX Power		-10 to -2dBm	±3dB	Internal
RX Power		-21 to -2dBm	±3dB	Internal

Recommended Application Interface Circuit

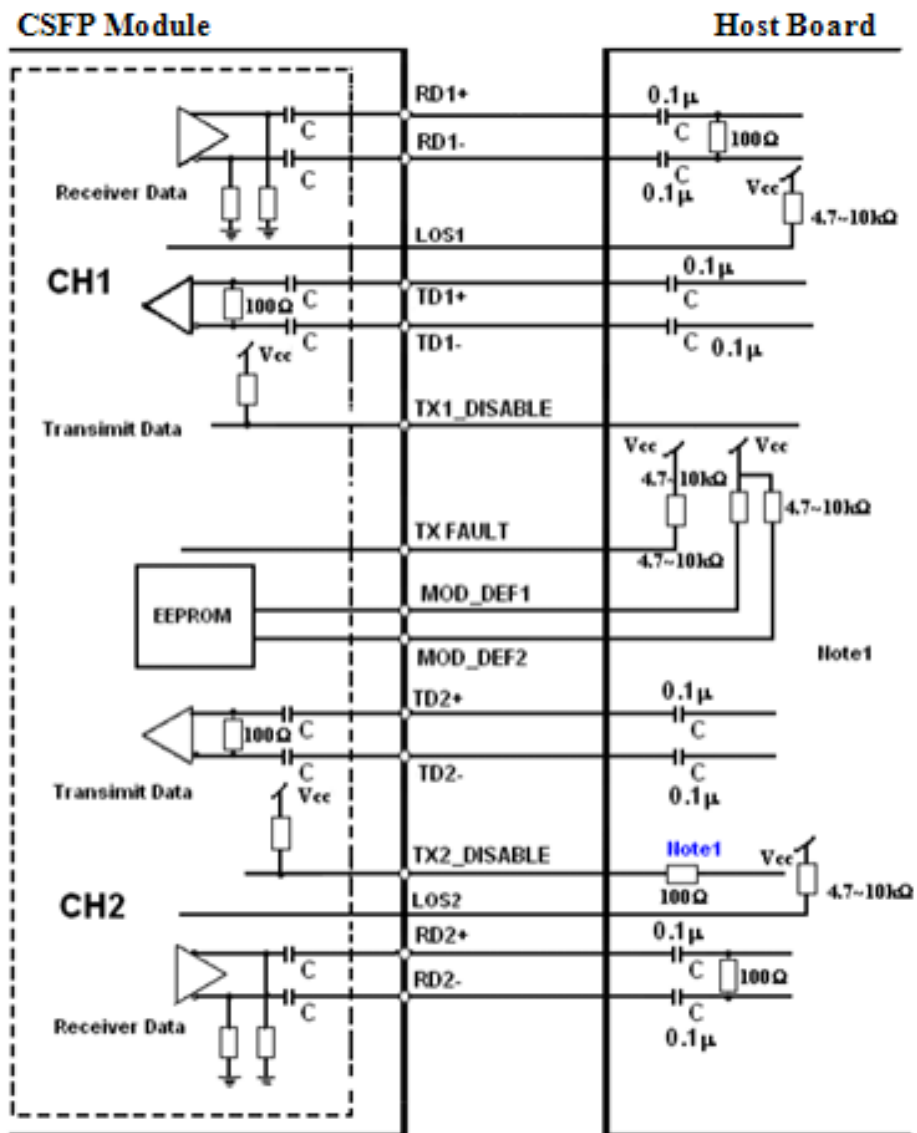

Figure 3. Recommended Application Interface Circuit

Note1: Recommendation 100 Ω series resistance on host board.

### Mechanical specifications

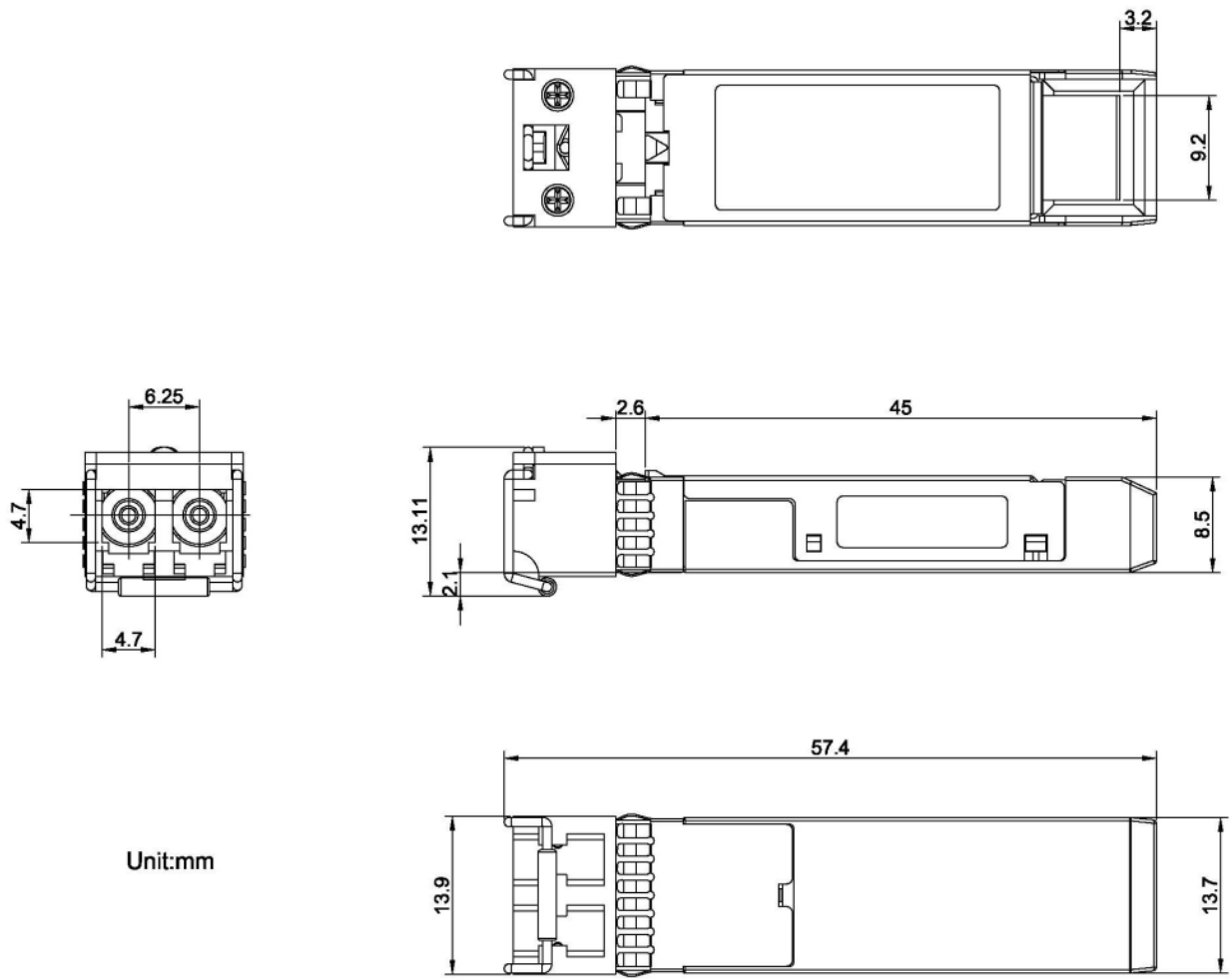

Figure 4. Outline Drawing

**Ordering information<sup>1</sup>**

Part Number	Description
XDB431-20LY	CSFP BIDI Transceiver 1490 nm TX/1310 nm RX, 1.25 Gbps, 20 km, -10°C ~ 70°C, DDM
XDB431-20LE	CSFP BIDI Transceiver 1490 nm TX/1310 nm RX, 1.25 Gbps, 20 km, -10°C ~ 85°C, DDM
XDB431-20LM	CSFP BIDI Transceiver 1490 nm TX/1310 nm RX, 1.25 Gbps, 20 km, -40°C ~ 85°C, DDM

**Notes:**

<sup>1</sup> For accurate order specification please contact XenOpt reseller before placing an order. The content of this document is subject to change without notice.

Please specify any host device compatibility requirements at the time of ordering. Standard MSA compatible pluggable components may not work, or some function of these components may not be available in devices that require customized pluggable devices. Pluggable components that are compatible with one type of communications equipment may not work in other type of communications equipment.

**Important Notice**

Performance figures, data and any illustrative material provided in this data sheet are contains typical values and must be specifically confirmed in writing by XenOpt before they become applicable to any particular order or contract. Specifications may change without notice

The publication of information in this data sheet does not imply freedom from of patent or other protective rights of XenOpt or others. Further details are available from any XenOpt sales representative.

To find out more, please contact: