

XSB541-80LM

1.25 Gbps SFP Bi-Directional Transceiver,
80 km Reach, 1550 nm TX/1490 nm RX

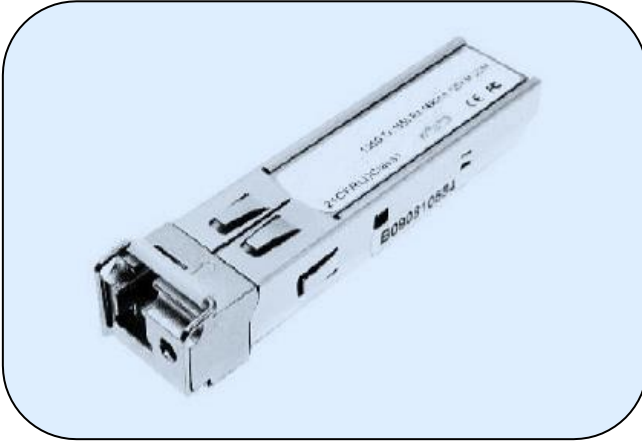

Features

- Rate of 1.25G bps operation
- 1550 nm DFB laser and PIN photodetector for 80 km transmission
- Compliant with SFP MSA and SFF-8472 with simplex LC receptacle
- Digital Diagnostic Monitoring: Internal Calibration or External Calibration
- Compatible with RoHS
- +3.3 V single power supply
- Operating case temperature:
- Military: -40 to +85°C

Applications

- Gigabit Ethernet
- Fiber Channel
- Switch to Switch interface
- Switched backplane applications
- Router/Server interface
- Other optical transmission systems

Description

The SFP-BIDI transceivers are high performance, cost effective modules with supporting rate of 1.25 Gbps and 80 km transmission distance with SMF.

The transceiver consists of three sections: a DFB laser transmitter, a PIN photodiode integrated with a trans-impedance preamplifier (TIA) and MCU control unit. All modules satisfy class I laser safety requirements.

The transceivers are compatible with SFP Multi-Source Agreement (MSA) and SFF-8472. For further information, please refer to SFP MSA.

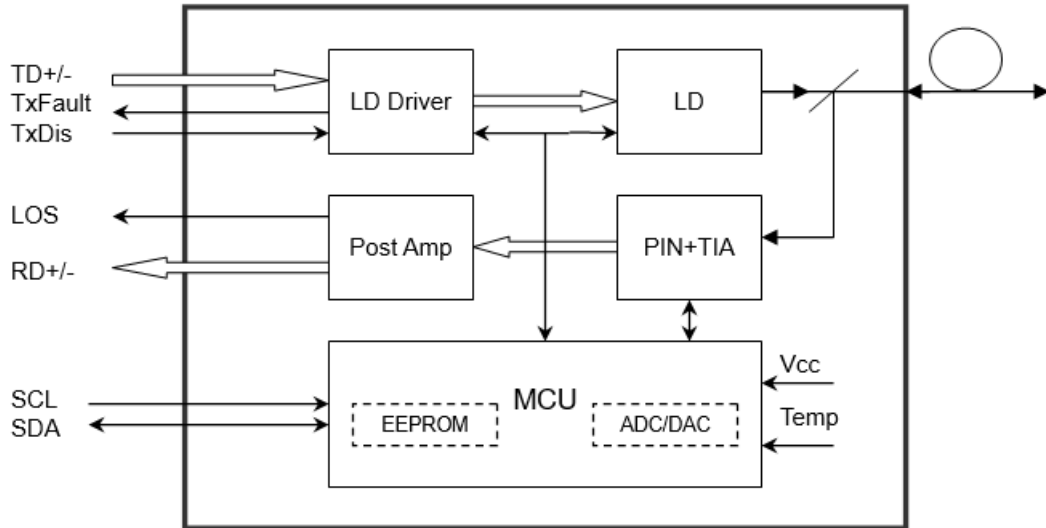

Absolute Maximum Ratings

Table 1. Absolute Maximum Ratings

Parameter	Symbol	Min	Max	Unit
Storage Temperature	T _s	-40	+85	°C
Operating Humidity	-	5	85	%
Supply Voltage	V _{cc}	-0.5	4.5	V

Recommended Operating Conditions

Table 2. Recommended Operating Conditions

Parameter	Symbol	Min	Typ	Max	Unit
Operating Case Temperature	Military T _c	-40		+85	°C
Power Supply Voltage	V _{cc}	3.13	3.3	3.47	V
Power Supply Current	I _{cc}			300	mA
Data Rate	Gigabit Ethernet		1.25		Gb/s
	Fiber Channel		1.063		

Optical and Electrical Characteristics

(DFB and PIN, 80 km Reach)

Table 3. Optical and Electrical Characteristics

Parameter	Symbol	Min	Typical	Max	Unit	Notes
Transmitter						
Centre Wavelength	λ_c	1530	1550	1570	nm	
Spectral Width (-20 dB)	$\Delta\lambda$			1	nm	
Side Mode Suppression Ratio	SMSR	30			dB	
Average Output Power	P_{out}	-2		+3	dBm	1
Extinction Ratio	ER	9			dB	
Optical Rise/Fall Time (20%~80%)	tr/tf			0.26	ns	
Data Input Swing Differential	V_{IN}	400		1800	mV	2
Input Differential Impedance	Z_{IN}	90	100	110	Ω	
TX Disable	Disable		2.0		Vcc	V
	Enable		0		0.8	V
TX Fault	Fault		2.0		Vcc	V
	Normal		0		0.8	V
Receiver						
Centre Wavelength	λ_c	1470		1510	nm	
Receiver Sensitivity				-25	dBm	3
Receiver Overload		-3			dBm	3
LOS De-Assert	LOS_D			-31	dBm	
LOS Assert	LOS_A	-35			dBm	
LOS Hysteresis		1		4	dB	
Data Output Swing Differential	V_{out}	400		1800	mV	4
LOS	High		2.0		Vcc	V
	Low			0.8	V	

Notes

1. The optical power is launched into SMF.
2. PECL input, internally AC-coupled and terminated.
3. Measured with a PRBS 2⁷-1 test pattern @1250 Mbps, BER $\leq 1 \times 10^{-12}$.
4. Internally AC-coupled.

Timing and Electrical

Table 4. Timing and Electrical

Parameter	Symbol	Min	Typical	Max	Unit
Tx Disable Negate Time	t_on			1	ms
Tx Disable Assert Time	t_off			10	μs
Time To Initialize, including Reset of Tx Fault	t_init			300	ms
Tx Fault Assert Time	t_fault			100	μs
Tx Disable To Reset	t_reset	10			μs
LOS Assert Time	t_loss_on			100	μs
LOS De-assert Time	t_loss_off			100	μs
Serial ID Clock Rate	f_serial_clock			400	KHz
MOD_DEF (0:2)-High	V _H	2		V _{cc}	V
MOD_DEF (0:2)-Low	V _L			0.8	V

Digital Diagnostic Memory Map

The transceivers provide serial ID memory contents and diagnostic information about the present operating conditions by the 2-wire serial interface (SCL, SDA).

The diagnostic information with internal calibration or external calibration all are implemented, including received power monitoring, transmitted power monitoring, bias current monitoring, supply voltage monitoring and temperature monitoring.

The digital diagnostic memory map specific data field defines as following.

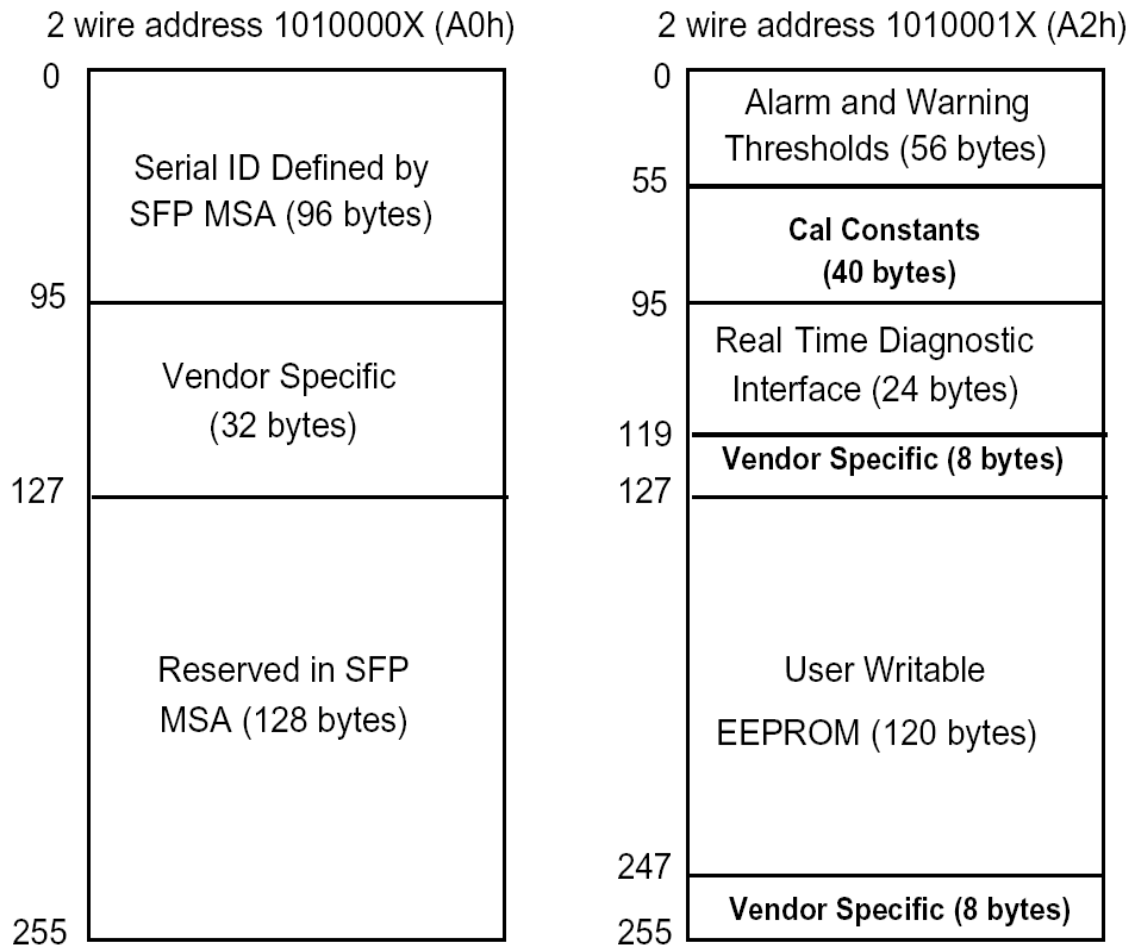

Pin Definitions

Pin Diagram

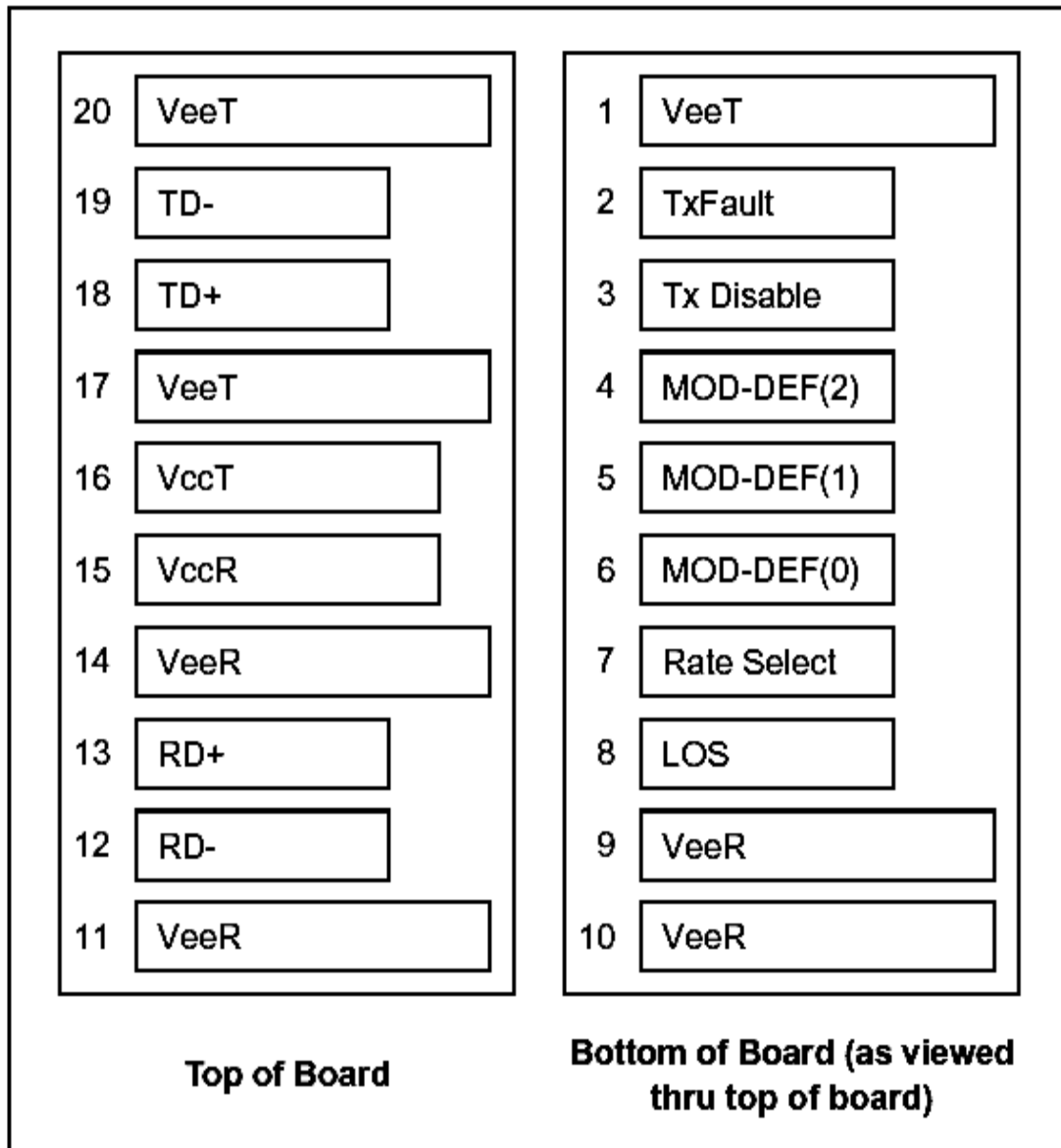

Pin Descriptions

Table 5. Pin Description

Pin	Signal Name	Description	Plug Seq.	Notes
1	V _{EET}	Transmitter Ground	1	
2	TX FAULT	Transmitter Fault Indication	3	Note 1
3	TX DISABLE	Transmitter Disable	3	Note 2
4	MOD_DEF(2)	SDA Serial Data Signal	3	Note 3
5	MOD_DEF(1)	SCL Serial Clock Signal	3	Note 3
6	MOD_DEF(0)	TTL Low	3	Note 3
7	Rate Select	Not Connected	3	
8	LOS	Loss of Signal	3	Note 4
9	V _{EER}	Receiver ground	1	
10	V _{EER}	Receiver ground	1	
11	V _{EER}	Receiver ground	1	
12	RD-	Inv. Received Data Out	3	Note 5
13	RD+	Received Data Out	3	Note 5
14	V _{EER}	Receiver ground	1	
15	V _{CCR}	Receiver Power Supply	2	
16	V _{CCT}	Transmitter Power Supply	2	
17	V _{EET}	Transmitter Ground	1	
18	TD+	Transmit Data In	3	Note 6
19	TD-	Inv. Transmit Data In	3	Note 6
20	V _{EET}	Transmitter Ground	1	

Notes

Plug Seq.: Pin engagement sequence during hot plugging.

- TX Fault is an open collector output, which should be pulled up with a 4.7 k~10 kΩ resistor on the host board to a voltage between 2.0 V and V_{cc}+0.3 V. Logic 0 indicates normal operation; Logic 1 indicates a laser fault of some kind. In the low state, the output will be pulled to less than 0.8 V.
- TX Disable is an input that is used to shut down the transmitter optical output. It is pulled up within the module with a 4.7 k~10 kΩ resistor. Its states are:
 - Low (0 to 0.8 V): Transmitter on
 - (>0.8 V, < 2.0 V): Undefined
 - High (2.0 to 3.465 V): Transmitter Disabled
 - Open: Transmitter Disabled
- Mod-Def 0,1,2. These are the module definition pins. They should be pulled up with a 4.7 k~10 kΩ resistor on the host board. The pull-up voltage shall be V_{ccT} or V_{ccR}.
 - Mod-Def 0 is grounded by the module to indicate that the module is present
 - Mod-Def 1 is the clock line of two wire serial interface for serial ID
 - Mod-Def 2 is the data line of two wire serial interface for serial ID
- LOS is an open collector output, which should be pulled up with a 4.7 k~10 kΩ resistor. Pull up voltage between 2.0 V and V_{cc}+0.3 V. Logic 1 indicates loss of signal; Logic 0 indicates normal operation. In the low state, the output will be pulled to less than 0.8 V.
- RD-/+ : These are the differential receiver outputs. They are internally AC-coupled 100 differential lines which should be terminated with 100 Ω (differential) at the user SERDES.
- TD-/+ : These are the differential transmitter inputs. They are internally AC-coupled, differential lines with 100 Ω differential termination inside the module.

Recommended Interface Circuit

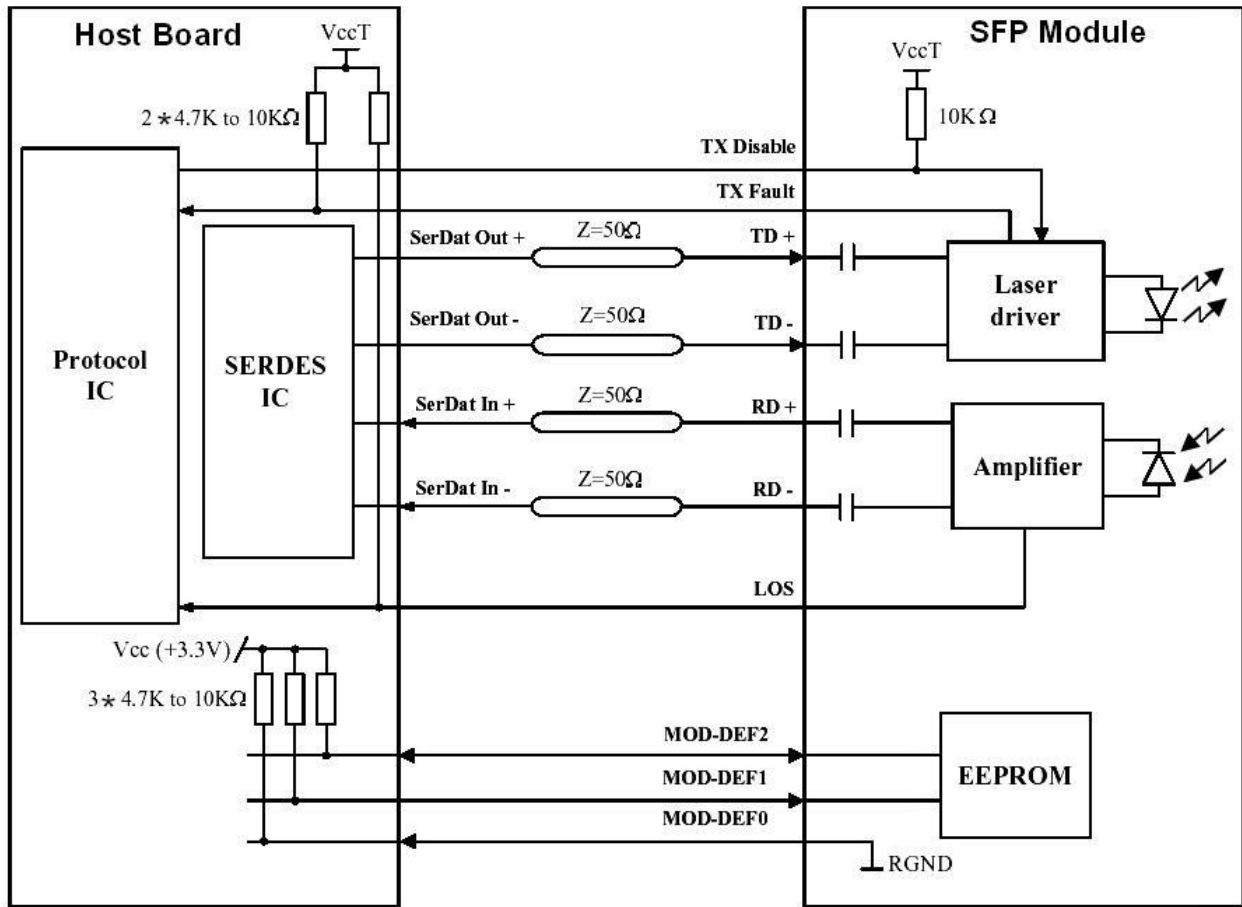

Mechanical Dimensions

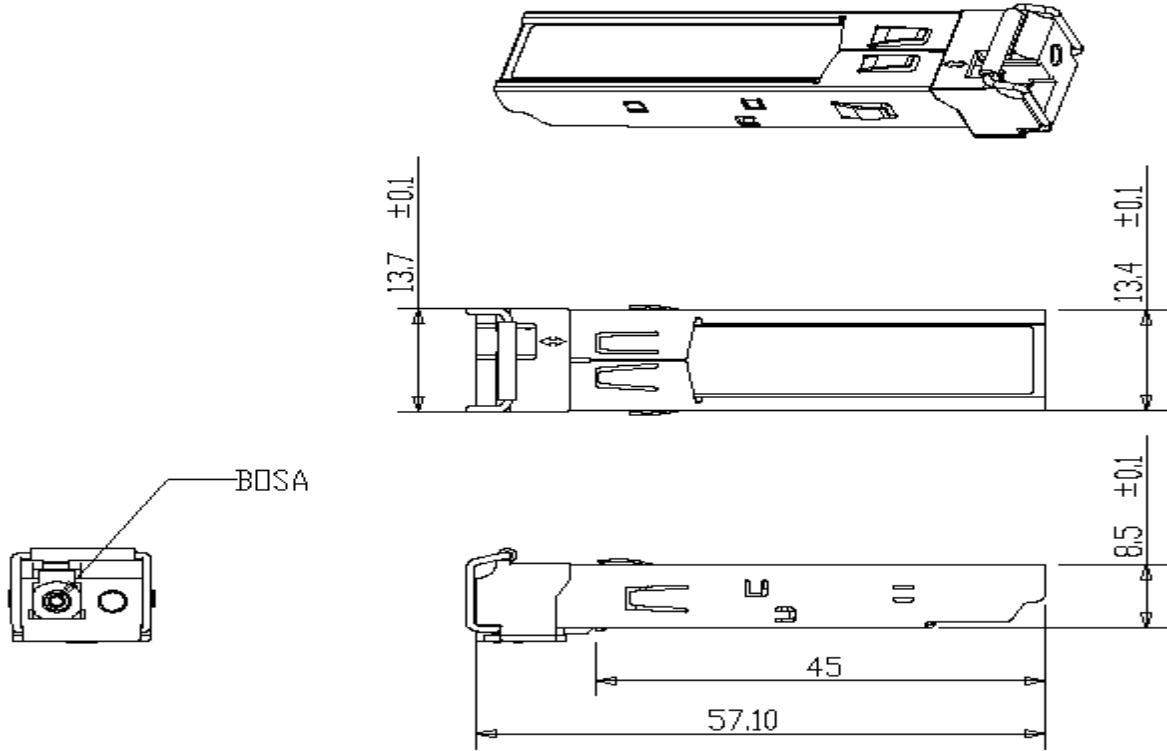

Ordering information¹

PN	Description
XSB541-80LM	SFP BIDI 1.25 Gbps, 1550 nm, 80 km, LC, DDM, -40°C ~ +85°C

Notes:

¹ Specification may change without notice. For accurate specification please contact XenOpt reseller before placing an order. The content of this document is subject to change without notice. Please specify any compatibility requirements at time of ordering. Standard MSA compatible pluggable components may not work or some function of these components may not be available in devices that require customized compatible devices. Pluggable components compatible with one type of communications equipment may not work in other type of communications equipment.

Important Notice

Performance figures, data and any illustrative material provided in this data sheet are typical and must be specifically confirmed in writing by XenOpt before they become applicable to any particular order or contract.

The publication of information in this data sheet does not imply freedom from patent or other protective rights of XenOpt or others. Further details are available from any XenOpt sales representative.

To find out more, please contact