

XTB325-30LY

25.78 Gbps SFP+ SM BIDI 1330 Tx/
1270 nm Rx 30 km Transceiver



Applications

- 25GBASE-LR

Features

- Supports high bit rates of up to 25.78 Gbps
- Utilizes a hot-pluggable SFP+ footprint
- Employs a 1330 nm DFB laser and PIN photodiode for up to 30 km transmission over single-mode fiber (SMF)
- Complies with SFP+ MSA and SFF-8472 standards, featuring a duplex LC receptacle
- Single +3.3 V power supply
- Real Time Digital Diagnostic Monitoring
- RoHS compatible
- Operating temperature range 0 °C to +70 °C (Standard)

Description

The SFP+ transceivers are cost-effective, high-performance modules designed to support a data rate of 25.78 Gbps and offer a transmission distance of up to 30 km using single-mode fiber (SMF).

These transceivers have three main components: a DFB laser transmitter, a PIN photodiode with an integrated trans-impedance preamplifier (TIA), and an MCU control unit. Note that all of these modules meet the safety requirements of class I lasers.

Furthermore, these transceivers adhere to the SFP Multi-Source Agreement and include SFF-8472 digital diagnostics functions for compatibility and performance monitoring.

Functional Diagram

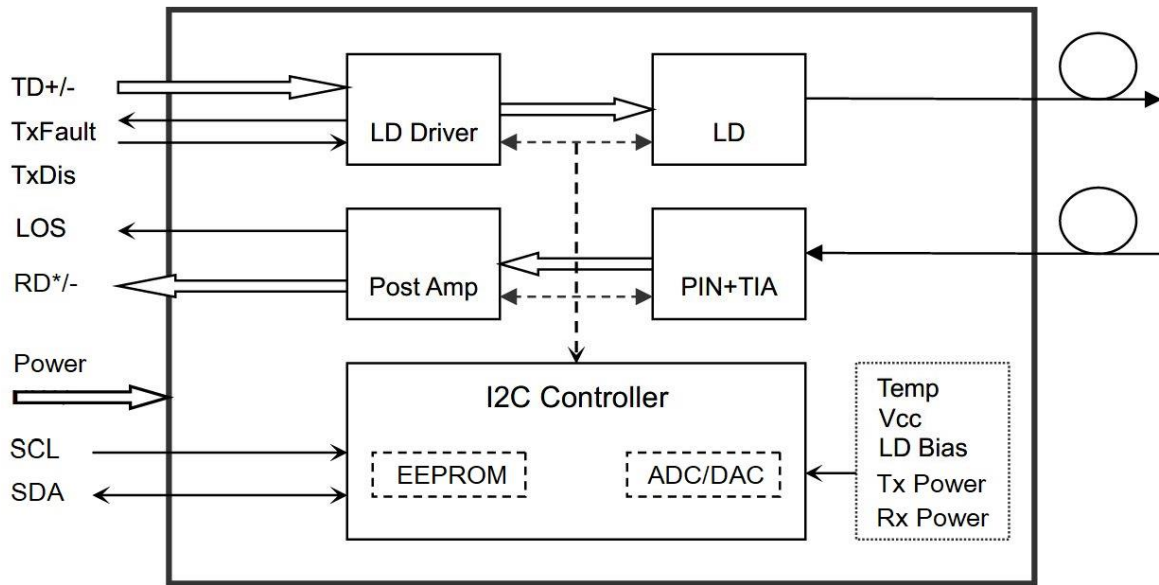

Absolute Maximum Ratings

Parameter	Symbol	Min	Max	Unit
Supply Voltage	Vcc	-0.5	4.5	V
Storage Temperature	Ts	-40	+85	°C
Operating Humidity	-	5	85	%

Recommended Operating Conditions

Parameter	Symbol	Min	Typical	Max	Unit
Operating Case Temperature	Tc	0		+70	°C
Power Supply Voltage	Vcc	3.135	3.30	3.465	V
Power Supply Current	Icc			400	mA
Data Rate			25.78		Gbps

Optical and Electrical Specifications

Parameter	Symbol	Min	Typical	Max	Unit	Notes
Transmitter						
Centre Wavelength	λ_c	1320	1330	1340	nm	
Spectral Width (-20dB)	$\Delta\lambda$			1	nm	
Side-Mode Suppression Ratio	SMSR	30	-		dB	
Average Output Power	P_{out}	-1		6	dBm	1
Extinction Ratio	ER	3.5			dB	
Data Input Swing Differential	V_{IN}	180		850	mV	2
Input Differential Impedance	Z_{IN}	90	100	110	Ω	
TX Disable	Disable		2.0	V_{cc}	V	
	Enable		0	0.8	V	
TX Fault	Fault		2.0	V_{cc}	V	
	Normal		0	0.8	V	
Receiver						
Centre Wavelength	λ_c	1260	1270	1280	nm	
Receiver Sensitivity				-19	dBm	3
Receiver Overload				2	dBm	3
LOS De-Assert	LOS_D			-15	dBm	
LOS Assert	LOS_A	-30			dBm	
LOS Hysteresis		0.5			dB	
Data Output Swing Differential	V_{out}	300		900	mV	4
LOS	High	2.0		V_{cc}	V	
	Low			0.8	V	

Notes

1. The optical power is launched into SMF
2. PECL input, internally AC-coupled and terminated
3. Measured with a PRBS 2³¹-1 test pattern @25.78 Gbps, BER $\leq 5 \times 10^{-5}$
4. Internally AC-coupled

Ordering information¹

Part number	Product Description
XTB325-30LY	SFP+ SM BIDI 25.78 Gbps Transceiver, 1330 Tx/1270 Rx ns, 30 km, LC, DDM, 0-70°C

Notes

¹ For accurate order specification please contact XenOpt reseller before placing an order. The content of this document is subject to change without notice. XenOpt does not guarantee errorless or outdated information.

Please specify any compatibility requirements at time of ordering. Standard MSA compatible pluggable components may not work or some function of these components may not be available in devices that require customized compatible devices. Pluggable components compatible with one type of communications equipment may not work in other type of communications equipment.

Important Notice

Performance figures, data and any illustrative material provided in this data sheet are typical and must be specifically confirmed in writing by XenOpt before they become applicable to any particular order or contract. In accordance with the XenOpt policy of continuous improvement specifications may change without notice.

The product image is only for reference purpose

The publication of information in this data sheet does not imply freedom from patent or other protective rights of XenOpt or others. Further details are available from any XenOpt sales representative.

To find out more, please contact: