

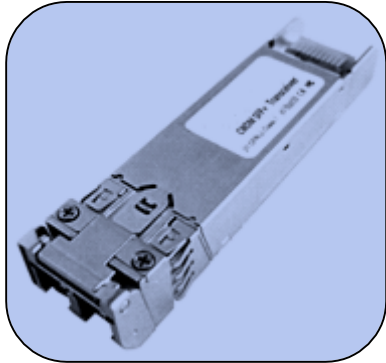

XTCxxA-80LY

10 Gbps 70 km CWDM SFP+ Transceiver

10 Gbps/s 70-80km CWDM SFP+ Transceiver



- Product Highlights**
- Compliant with SFF-8431 and IEE802.3ae
 - 10GBASE-ZR, and 2G/4G/ 8G/10G Fiber Channel applications
 - Wavelength selectable to ITU-T standards covering CWDM grid wavelengths
 - Cooled EML transmitter and APD receiver
 - Link length up to 70 km (1450 ps/nm@G652 fiber)
 - Low Power Dissipation 1.4W Typical (Maximum: 2W)
 - -5°C to 70°C Operating Case Temperature
 - Single 3.3V power supply
 - Diagnostic Performance Monitoring of module temperature, supply Voltages, laser bias current, transmit optical power, receive optical power
 - RoHS compliant and lead free

Applications

- 10G Ethernet
- 10G Fiber Channel
- CWDM Networks



Description

XenOpt SFP+ZR CWDM Transceiver is a “Limiting module”, designed for 10G Ethernet, and 2G/4G/ 8G/10G Fiber- Channel applications.

The transceiver consists of two sections: The transmitter section incorporates a cooled EML laser. And the receiver section consists of a APD photodiode integrated with a TIA. All modules satisfy class I laser safety requirements. Digital diagnostics functions are available via a 2-wire serial interface, as specified in SFF-8472, which allows real-time access to device operating parameters such as transceiver temperature, laser bias current, transmitted optical power, received optical power and transceiver supply voltage.

Absolute maximum rating

Parameters	Symbol	Min.	Max.	Unit
Power Supply Voltage	V _{CC}	-0.5	3.8	V
Storage Temperature	T _{st}	-40	85	°C
Relative Humidity	R _h	0	85	%

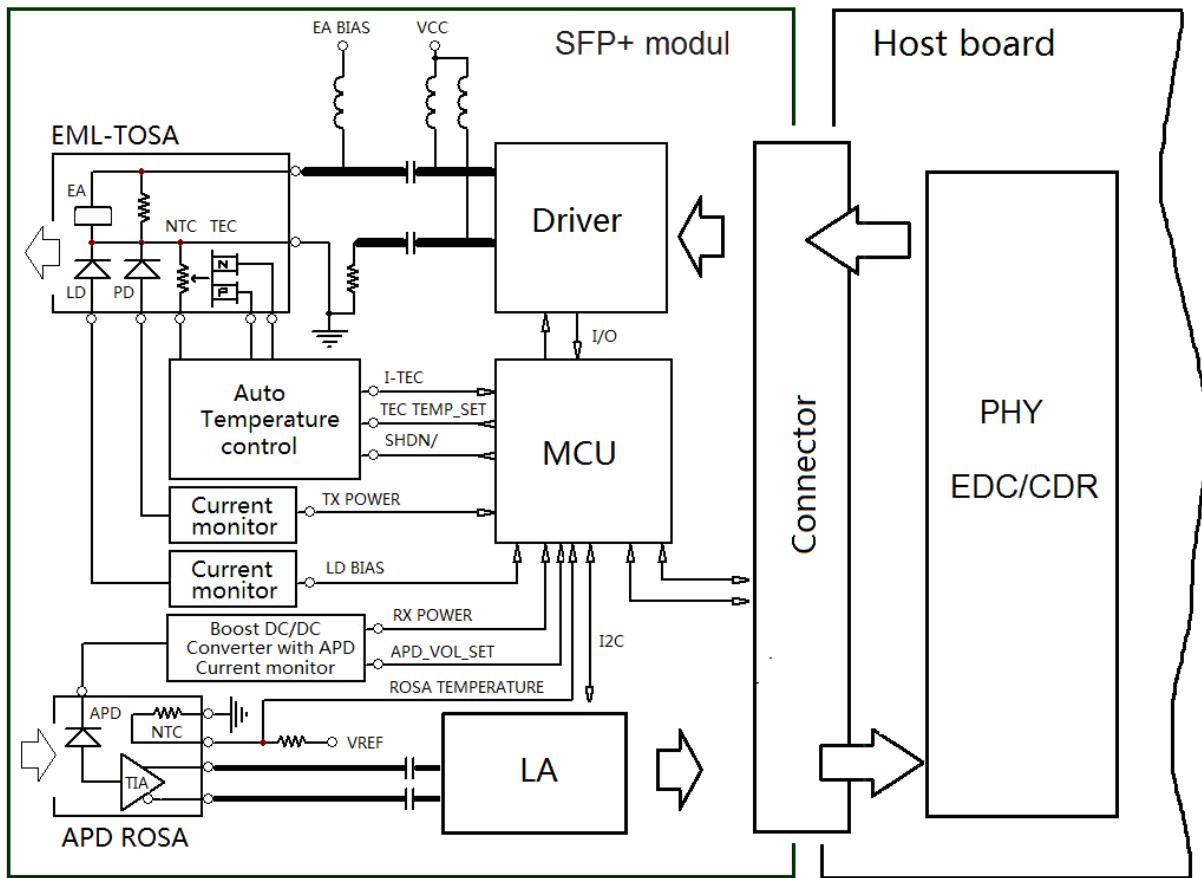

Gigalight 2011 --HHC

Figure 1. Module Block Diagram

Operating Conditions

Parameters	Symbol	Min	Typical	Max	Unit
Supply Voltage	Vcc	3.13	3.3	3.47	V
Supply Current	Icc		420	610	mA
Operating Case temperature	Tca	-5		70	°C
Module Power Dissipation	Pm	-	1.4	2	W

Notes:

- [1] Supply current is shared between VCCTX and VCCR.X.
- [2] In-rush is defined as current level above steady state current requirements.

Transmitter Specifications - Optical

Parameter	Symbol	Min	Typical	Max	Unit
Center Wavelength	λ_c	1464.5		1617.5	nm
Center wavelength stability	$\Delta\lambda_D$	-6.5	λ_c	6.5	nm
Spectral Width (-20 dB)	$\Delta\lambda_{20}$	-	-	0.3	nm
Average Optical Power	Po	0	-	+3	dBm
Side Mode Suppression Ratio	SMSR	30	-	-	dB
Optical Transmit Power (disabled)	PTX_DISABLE	-	-	-30	dBm
Extinction Ratio	ER	8.2	-	-	dB
Dispersion penalty (1450 ps/nm) [2]	DP	-	-	2	dB
Relative Intensity Noise	RIN	-	-	-128	dB/Hz
Optical Return Loss Tolerance	Orl	-	-	21	dB

Receiver Specifications – Optical

Parameter	Symbol	Min	Typical	Max	Unit
Input Operating Wavelength	λ	1260	-	1610	nm
Receiver sensitivity(Average) [1]					
Receiver sensitivity@9.95G	Rsen1			-24.5	dBm
Receiver sensitivity@10.3125G	Rsen2	-	-	-24	
Receiver sensitivity@11.1G	Rsen3			-22	
Maximum Input Power	RX-	-7	-		dBm
Path penalty at 1450ps/nm @9.95Gb/s	DP1			2	dB
Path penalty at 1450ps/nm @10.3125Gb/s	DP2			3	dB
Path penalty at 1300ps/nm @11.1Gb/s	DP3			3	dB
Loss of Signal Asserted	Lsa	-34	-	-	dBm
LOS De-Asserted	Lda	-	-	-24	dBm
LOS Hysteresis	Lh	0.5	-	-	dB

Notes:

[1] Measured with conformance test signal for BER = 10^{-12} . The stressed sensitivity values in the table are for system level BER measurements which include the effects of CDR circuits. It is recommended that at least 0.4 dB additional margin be allocated if component level measurements are made without the effects of CDR circuits.

Transmitter Specifications – Electrical

Parameters	Symbol	Min.	Typical	Max.	Unit
Data Rate	Mra	-	10.3	11.3	Gbps
Input differential impedance	Rim	-	100	-	Ω
Differential data Input	VtxDIFF	120	-	850	mV
Transmit Disable Voltage	VD	2.0	-	Vcc3+0.3	V
Transmit Enable Voltage	Ven	0	-	+0.8	V
Transmit Disable Assert Time	Vn	-	-	100	us

Receiver Specifications – Electrical

Parameters	Symbol	Min.	Typical	Max.	Unit
Data Rate	Mra	-	10.3125	11.1	Gbps
Differential Output Swing	Vout P-P	350	-	850	mV
Rise/Fall Time	Tr / Tf	-	-	40-	ps
Loss of Signal –Asserted	VOH	2	-	Vcc3+0.3-	V
Loss of Signal –Negated	VOL	0	-	+0.4	V

Digital Diagnostic Functions

Parameter	Symbol	Min.	Max	Unit	Notes
Accuracy					
Transceiver Temperature	DMI_Temp	-3	+3	degC	Over operating temp
TX Output optical power	DMI_TX	-3	+3	dB	
RX Input optical power	DMI_RX	-3	+3	dB	-7dBm to -26dBm range
Transceiver Supply voltage	DMI_VCC	-0.08	+0.08	V	Full operating range
Bias current monitor	DMI_Ibias	-10%	10%	mA	
Dynamic Range Accuracy					
Transceiver Temperature	DMI_Temp	-5	70	degC	
TX Output optical power	DMI_TX	0	+3	dBm	
RX Input optical power	DMI_RX	-26	-7	dBm	
Transceiver Supply voltage	DMI_VCC	3.0	3.6	V	
Bias current monitor	DMI_Ibias	0	100	mA	

Pin Definition

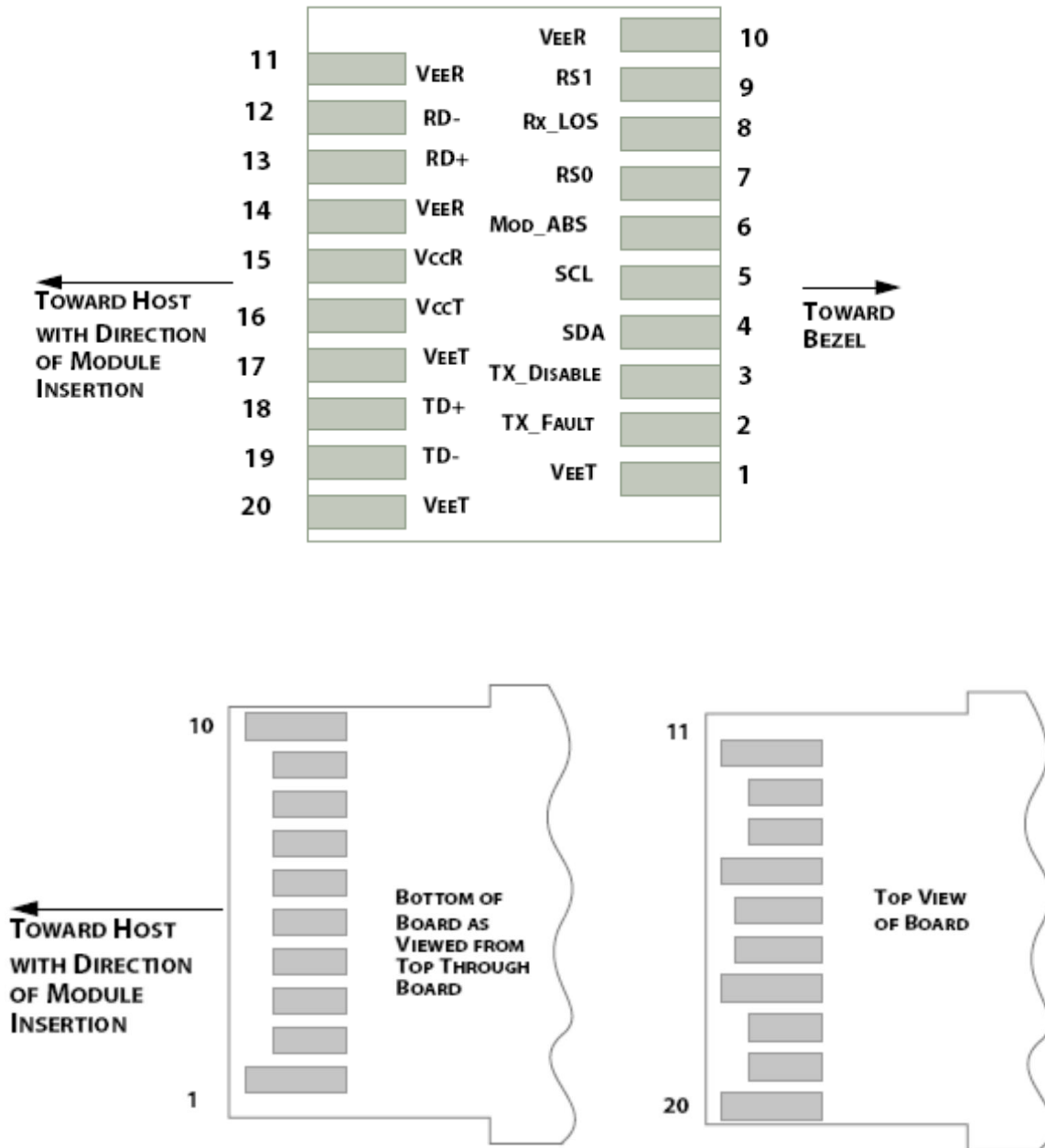

Figure 2. Electrical Pin-out Details

PIN descriptions

Pin	Symbol	Name/Description
1	VeeT [1]	Transmitter Ground
2	TX_FAULT [2]	Transmitter Fault
3	TX_DIS [3]	Transmitter Disable. Laser output disabled on high or open
4	SDA [2]	2-Wire Serial Interface Data Line
5	SCL [2]	2-Wire Serial Interface Clock Line
6	MOD_ABS [4]	Module Absent. Grounded within the module
7	RS0 [5]	Rate Select 0
8	RX_LOS [2]	Loss of Signal Indication. Logic 0 indicates normal operation
9	RS1 [5]	Rate Select 1
10	VEER [1]	Receiver Ground
11	VEER [1]	Receiver Ground
12	RD-	Receiver Inverted DATA out. AC Coupled
13	RD+	Receiver DATA Out. AC Coupled
14	VEER [1]	Receiver Ground
15	VCCR	Receiver Power Supply
16	VCCT	Transmitter Power Supply
17	VEET [1]	Transmitter Ground
18	TD+	Transmitter DATA in. AC Coupled
19	TD-	Transmitter Inverted DATA in. AC Coupled
20	VEET [1]	Transmitter Ground

Notes:

[1] Module circuit ground is isolated from module chassis ground within the module.

[2] Should be pulled up with 4.7k – 10k ohms on host board to a voltage between 3.15V and 3.6V.

[3] Tx_Disable is an input contact with a 4.7 kΩ to 10 kΩ pullup to VccT inside the module.

[4] Mod_ABS is connected to VeeT or VeeR in the SFP+ module. The host may pull this contact up to Vcc_Host with a resistor in the range 4.7 kΩ to 10 kΩ. Mod_ABS is asserted “High” when the SFP+ module is physically absent from a host slot.

[5] RS0 and RS1 are module inputs and are pulled low to VeeT with > 30 kΩ resistors in the module.

Circuit Diagram

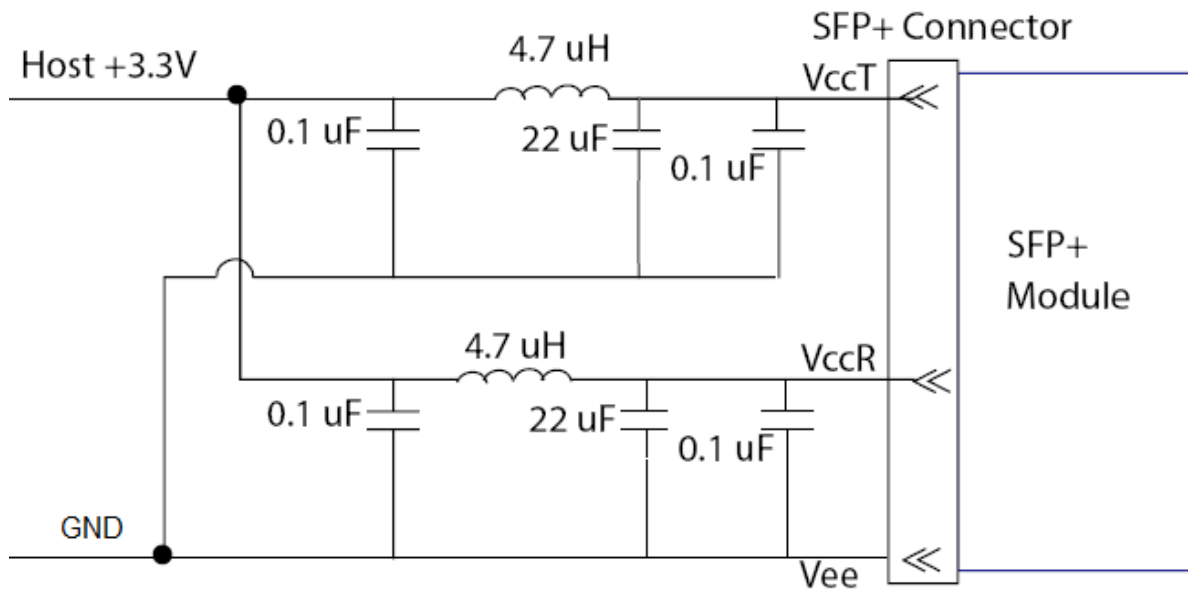

Figure 3. Host Board Power Supply Filters Circuit

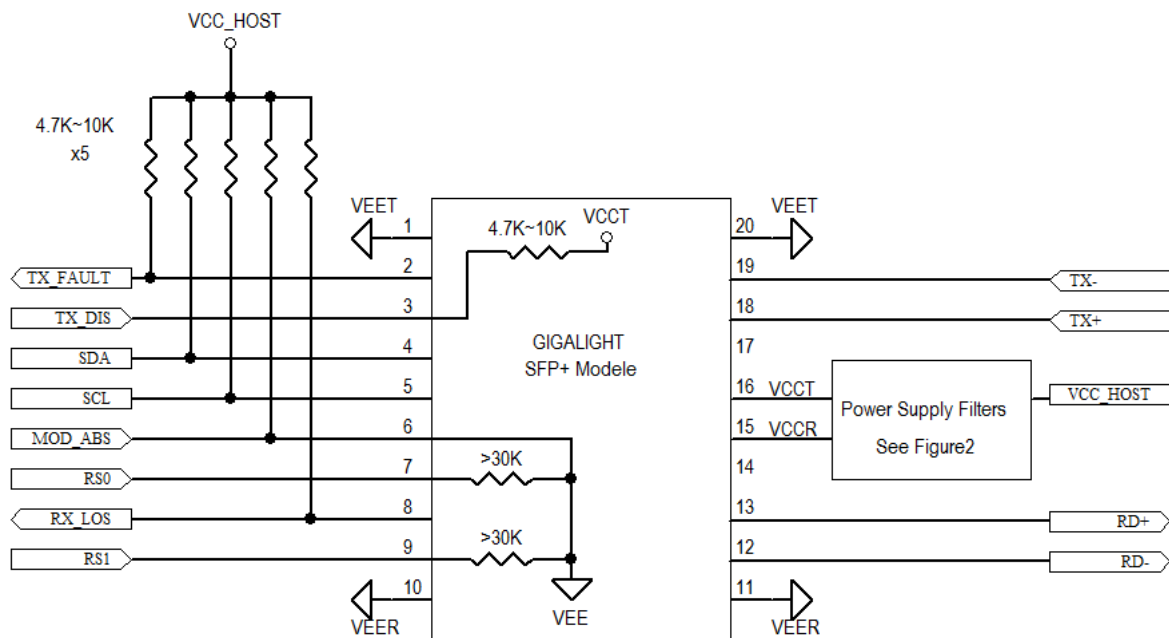

Figure 4. Host-Module Interface

Mechanical Dimensions

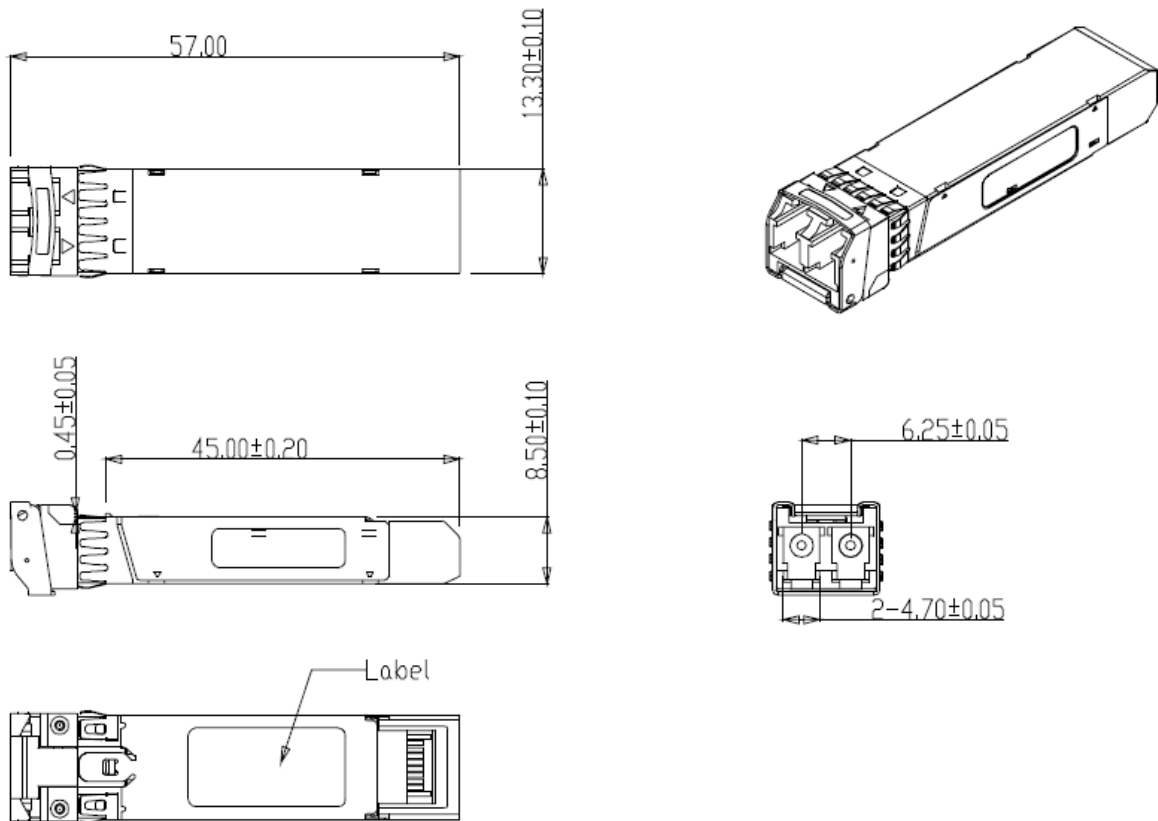

Figure 4. Mechanical Specifications

Regulatory Compliance

XenOpt SFP+ transceiver is designed to be Class I Laser safety compliant and is certified per the following standards:

Feature	Agency	Standard	Certificate / Comments
Laser Safety	FDA	CDRH 21 CFR 1040 and Laser Notice No. 50	1120292-000
Product Safety	UL	UL and CUL EN60950-2:2007	E347511
Environmental protection	SGS	RoHS Directive 2002/95/EC	GZ1001008918/CHEM
EMC	WALTEK	EN 55022:2006+A1:2007 EN 55024:1998+A1+A2:2003	WT10093759-D-E-E

Ordering information

Part Number	Product Description
XTC47A-80LY	10 Gbps, 1470 nm SFP+ZR 80 km, -5°C ~ +70°C
XTC49A-80LY	10 Gbps, 1490 nm SFP+ZR 80 km, -5°C ~ +70°C
XTC51A-80LY	10 Gbps, 1510 nm SFP+ZR 80 km, -5°C ~ +70°C
XTC53A-80LY	10 Gbps, 1530 nm SFP+ZR 80 km, -5°C ~ +70°C
XTC55A-80LY	10 Gbps, 1550 nm SFP+ZR 80 km, -5°C ~ +70°C
XTC57A-80LY	10 Gbps, 1570 nm SFP+ZR 80 km, -5°C ~ +70°C
XTC59A-70LY	10 Gbps, 1590 nm SFP+ZR 80 km, -5°C ~ +70°C
XTC61A-87LY	10 Gbps, 1610 nm SFP+ZR 80 km, -5°C ~ +70°C

Notice. Please specify any compatibility requirements at time of ordering. Standard MSA compatible pluggable components may not work or some function of these components may not be available in devices that require customized compatible devices. Pluggable components compatible with one type of communications equipment may not work in other type of communications equipment.

References

1. "Specifications for Enhanced Small Form Factor Pluggable Module SFP+", SFF-8431, Rev 4.1, July 6, 2009.
2. "Improved Pluggable Formfactor", SFF-8432, Rev 4.2, Apr 18, 2007
3. IEEE802.3ae – 2002
4. "Diagnostic Monitoring Interface for Optical Transceivers" SFF-8472, Rev 10.3, Dec 1, 2007

Important Notice

Performance figures, data and any illustrative material provided in this data sheet are typical and must be specifically confirmed in writing by XenOpt before they become applicable to any particular order or contract. In accordance with the XenOpt policy of continuous improvement specifications may change without notice.

The publication of information in this data sheet does not imply freedom from patent or other protective rights of XenOpt or others. Further details are available from any XenOpt sales representative.

To find out more, please contact:



www.xenopt.com