



XTM855-xxLY

25 Gbps 850 nm Multimode SFP28 Transceiver



Product Highlights

- 25 Gb/s serial optical interface
- 850 nm VCSEL transmitter, PIN photo detector
- 2-wire interface for management specifications compliant with SFF 8472 digital diagnostic monitoring interface for optical transceivers
- Operating case temperature: 0 °C to 70 °C
- All-metal housing for superior EMI performance
- Low power consumption
- Advanced firmware allow customer system encryption information to be stored in transceiver
- Cost effective SFP28 solution, enables higher port densities and greater bandwidth
- RoHS compliant

Applications

- High-speed storage area networks
- Computer cluster cross-connect
- Custom high-speed data pipes
- Inter Rack Connection

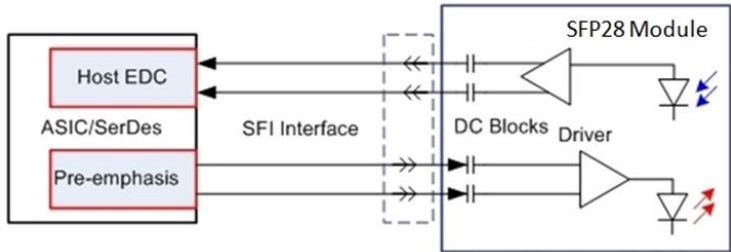

Figure 1: Application in System

1. General Description

This 850 nm VCSEL 25 Gigabit SFP28 transceiver is designed to transmit and receive optical data over 50 μm multimode optical fiber (Table 1).

The SFP28 SR module electrical interface is compliant to SFI electrical specifications. The transmitter input and receiver output impedance is 100 Ohms differential. Data lines are internally AC coupled. The module provides differential termination and reduce differential to common mode conversion for quality signal termination and low EMI. SFI typically operates over 200 mm of improved FR4 material or up to about 150mm of standard FR4 with one connector.

The transmitter converts 25Gbit/s serial PECL or CML electrical data into serial optical data compliant with the 25GBASE-SR standard. An open collector compatible Transmit Disable (Tx_Dis) is provided. Logic "1" or no connection on this pin will disable the laser from transmitting. Logic "0" on this pin provides normal operation. The transmitter has an internal automatic power control loop (APC) to ensure constant optical power output across supply voltage and temperature variations. An open collector compatible Transmit Fault (Tx_Fault) is provided. TX_Fault is module output contact that when high, indicates that the module transmitter has detected a fault condition related to laser operation or safety. The TX_Fault output contact is an open drain/collector and shall be pulled up to the Vcc_Host in the host with a resistor in the range 4.7-10 k Ω . TX_Disable is a module input contact. When TX_Disable is asserted high or left open, the SFP28 module transmitter output shall be turned off. This contact shall be pulled up to VccT with a 4.7 k Ω to 10 k Ω resistor.

The receiver converts 25Gbit/s serial optical data into serial PECL/CML electrical data. An open collector compatible Loss of Signal is provided. Rx_LOS when high indicates an optical signal level below that specified in the relevant standard. The Rx_LOS contact is an open drain/collector output and shall be pulled up to Vcc_Host in the host with a resistor in the range 4.7-10 k Ω , or with an active termination. Power supply filtering is recommended for both the transmitter and receiver. The Rx_LOS signal is intended as a preliminary indication to the system in which the SFP28 is installed that the received signal strength is below the specified range. Such an indication typically points to non-installed cables, broken cables, or a disabled, failing or a powered off transmitter at the far end of the cable.

Fiber type	850 nm OFL Bandwidth	Supported Distances (meters)
50 μm MMF	OM4 (2000 MHz-km)	2 to 100
50 μm MMF	OM3 (2000 MHz-km)	2 to 70

Table 1: SFP28 SR Operating Range for each Optical Fiber Type

2. Proposed Application Schematics

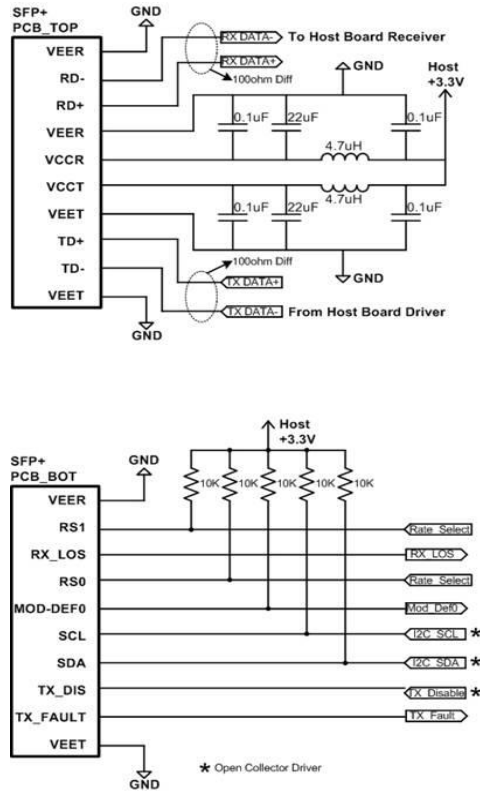

Figure 2

3. Pin Definition

The SFP28 modules are hot-pluggable. Hot pluggable refers to plugging in or unplugging a module while the host board is powered. The SFP28 host connector is a 0.8 mm pitch 20 position right angle improved connector specified by SFF-8083, or stacked connector with equivalent with equivalent electrical performance. Host PCB contact assignment is shown in Figure 4 and contact definitions are given in the PIN description table. SFP28 module contacts mates with the host in the order of ground, power, followed by signal as illustrated by Figure 5 and the contact sequence order listed in the PIN description table.

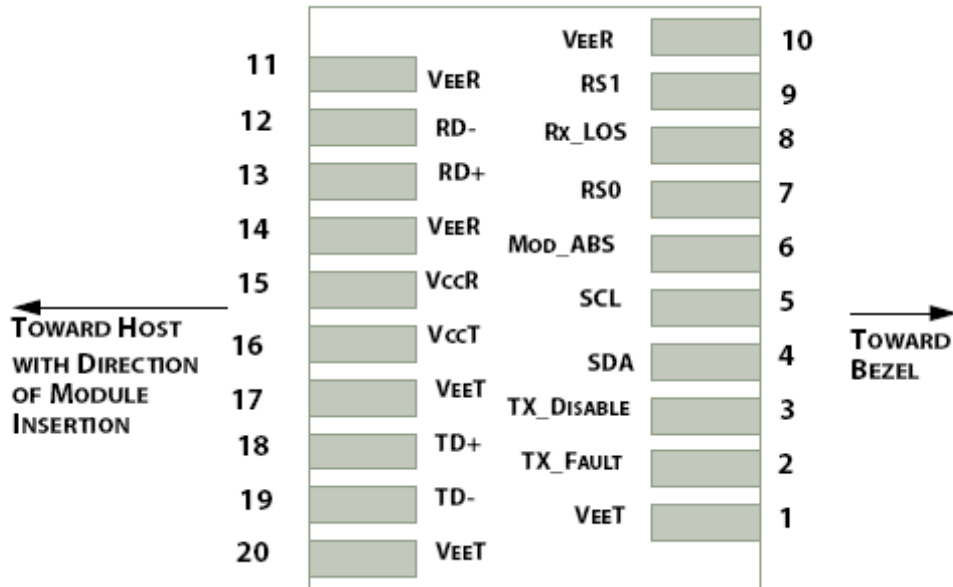

Figure 3: Module Interface to Host

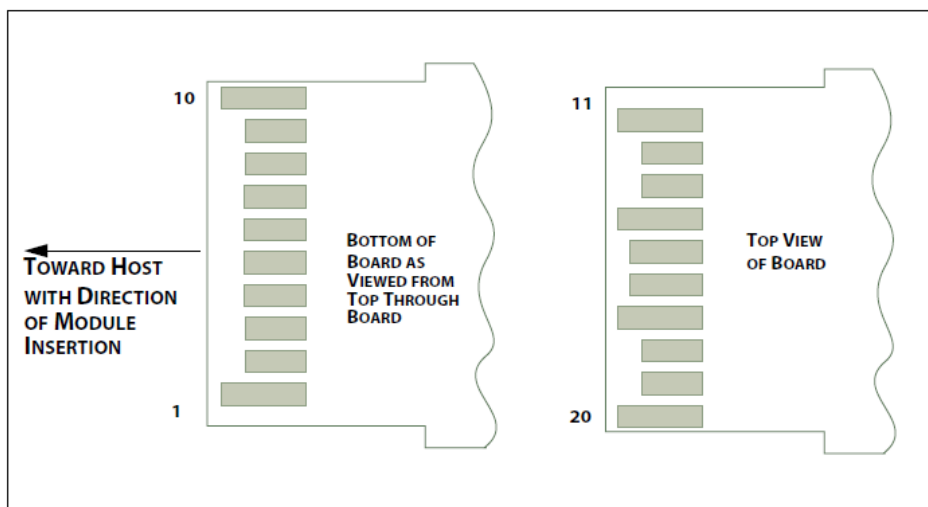

Figure 4: Module Contact

PIN description

Pin	Logic	Symbol	Name/Description	Note
1		VeeT	Module Transmitter Ground	1
2	LVTTL-O	TX_Fault	Module Transmitter Fault	
3	LVTTL-I	TX_Dis	Transmitter Disable; Turns off transmitter laser output	
4	LVTTL-I/O	SDA	2-Wire Serial Interface Data Line	2
5	LVTTL-I	SCL	2-Wire Serial Interface Clock	2
6		MOD_DEF0	Module Definition, Grounded in the module	
7	LVTTL-I	RS0	Receiver Rate Select	
8	LVTTL-O	RX_LOS	Receiver Loss of Signal Indication Active LOW	
9	LVTTL-I	RS1	Transmitter Rate Select (not used)	
10		VeeR	Module Receiver Ground	1
11		VeeR	Module Receiver Ground	1
12	CML-O	RD-	Receiver Inverted Data Output	
13	CML-O	RD+	Receiver Data Output	
14		VeeR	Module Receiver Ground	1
15		VccR	Module Receiver 3.3 V Supply	
16		VccT	Module Receiver 3.3 V Supply	
17		VeeT	Module Transmitter Ground	1
18	CML-I	TD+	Transmitter Non-Inverted Data Input	
19	CML-I	TD-	Transmitter Inverted Data Input	
20		VeeT	Module Transmitter Ground	1

Notes:

1. Module ground pins GND are isolated from the module case.
2. Shall be pulled up with 4.7K-10Kohms to a voltage between 3.15V and 3.45V on the host board.

4. Transceiver Block Diagram

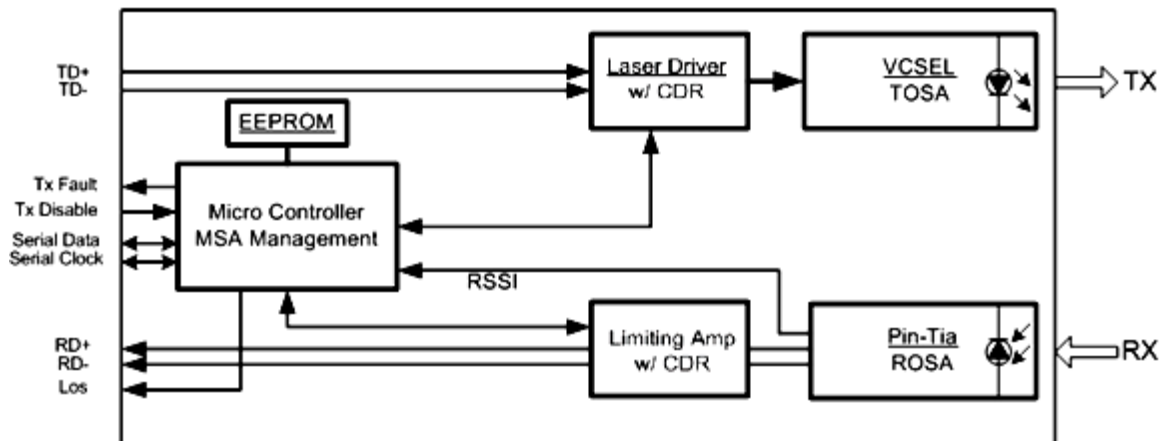

5. Absolute maximum rating

These values represent the damage threshold of the module. Stress in excess of any of the individual Absolute Maximum Ratings can cause immediate catastrophic damage to the module even if all other parameters are within Recommended Operating Conditions.

Parameters	Symbol	Min.	Max.	Unit
Power Supply Voltage	V_{CC}	0	3.6	V
Storage Temperature	T_{st}	-40	85	°C
Operating Case Temperature	T_c	0	70	°C
Relative Humidity	RH	5	95	%
Damage Threshold	P_{max}	3		dBm

6. Recommended Operating Environment

Recommended Operating Environment specifies parameters for which the electrical and optical characteristics hold unless otherwise noted.

Parameters	Symbol	Min.	Typical	Max.	Unit
Power Supply Voltage	V_{CC}	3.135	3.3	3.465	V
Power Supply Current	I_{CC}			300	mA
Operating Case temperature	T_{ca}	0	25	70	°C

7. Optical Characteristics

The following optical characteristics are defined over the Recommended Operating Environment unless otherwise specified.

Parameters	Symbol	Min.	Typical	Max.	Unit	Notes
Transmitter						
Center Wavelength	λ_t	840	850	860	nm	
RMS spectral width	Pm	-	-	0.6	nm	1
Average Optical Power	Pavg	-8.4	-	2.4	dBm	
Optical Power OMA	Poma	-6.4	-1.5	3	dBm	1
Laser Off Power	Poff	-	-	-30	dBm	
Extinction Ratio	ER	2	-	-	dB	
Transmitter Dispersion Penalty	TDP	-	-	-	dB	TBD
Relative Intensity Noise	Rin	-	-	-	dB/Hz	12dB reflection
Optical Return Loss Tolerance		-	-	12	dB	
Receiver						
Center Wavelength	λ_r	840	850	860	nm	
Receiver Sensitivity (OMA)	Psens	-	-	-10	dBm	
Stressed Sensitivity (OMA)		-	-	-5.2	dBm	
LOS Assert	LOSA	-	-	-	dBm	TBD
LOS Deassert	LOSD	-	-	-	dBm	TBD
LOS Hysteresis	LOSH	-	-	-	dB	TBD
Overload	Pin	-	-	3.5	dBm	
Receiver Reflectance		-	-	-12	dB	

Note1: Per Tradeoff Table 52.8, IEEE 802.3ae 2005

8. Digital Diagnostic Functions

The following digital diagnostic characteristics are defined over the Recommended Operating Environment unless otherwise specified. It is compliant to SFF8472 Rev11 with internal calibration mode. For external calibration mode please contact our sales.

Parameters	Symbol	Min.	Max.	Unit	Notes
Temperature monitor absolute error	DMI_Temp	-3	3	degC	Over operating temp
Laser power monitor absolute error	DMI_TX	-3	3	dB	
RX power monitor absolute error	DMI_RX	-3	3	dB	-1dBm to -12dBm range
Supply voltage monitor absolute error	DMI_VCC	-0.1	0.1	V	Full operating range
Bias current monitor	DMI_Ibias	-10%	10%	mA	

9. Electrical Characteristics

The following electrical characteristics are defined over the Recommended Operating Environment unless otherwise specified.

Parameters	Symbol	Min.	Typical	Max.	Unit	Notes
Data Rate		-	25.78	-	Gbps	
Power Consumption		-	800	1000	mW	
Transmitter						
Single Ended Output Voltage Tolerance		-0.3	-	4	V	
C common mode voltage tolerance		15	-	-	mV	
Tx Input Diff Voltage	VI	180		700	mV	
Tx Fault	VoL	-0.3		0.4	V	At 0.7mA
Data Dependent Input Jitter	DDJ			-	UI	TBD
Data Input Total Jitter	TJ			-	UI	TBD
Receiver						
Single Ended Output Voltage Tolerance		-0.3	-	4	V	
Rx Output Diff Voltage	Vo	300		900	mV	
Rx Output Rise and Fall Time	Tr/Tf	9.5			ps	20% to 80%
Total Jitter	TJ			-	UI	TBD
Deterministic Jitter	DJ			-	UI	TBD

10. Control and Status I/O Timing Characteristics

Timing characteristics of control and status I/O are included in Table.

Parameter	Symbol	Min.	Max.	Unit	Conditions
TX_Disable assert time	t_off		100	μs	Rising edge of TX_Disable to fall of output signal below 10% of normal
TX_Disable negate time	t_on		2	ms	Falling edge of TX_Disable to rise of output signal above 90% of normal operation, not during start up of fault recovery.
Time to initialize 2-wire interface	t_2w_start_up		300	ms	From power on or hot plug meeting mechanical dimensions
Time to initialize	t_start_up		300	ms	From power supply meeting mechanical dimensions or hot plug, or Tx_disable negated power up or Tx_Fault recovery, until non-cooled power level I part (or non-cooled power level II part already enabled at power level II for Tx_Fault recovery) is fully operational.
Time to initialize cooled module	t_start_up_cooled		90	s	From power supply meeting mechanical dimensions or hot plug, or Tx_disable negated power up or Tx_Fault recovery, until non-cooled power level I part (or cooled power level II part part during fault recovery) is fully operational.
Time to Power Up to Level II	t_power_lev2		300	ms	From falling edge of stop bit enabling power level II until non-cooled module is fully operational.
Time to Power Down from Level II	t_power_down		300	ms	From falling edge of stop bit disabling power level II until within power level I requirements.
TX_Fault assert	TX_Fault_on		1	ms	From occurrence of fault to assertion of TX_Fault.
TX_Fault assert for cooled module	TX_Fault_on_cooled		50	ms	From occurrence of fault to assertion of TX_Fault.
TX_Fault Reset	t_reset	10		μs	Time TX_Disable must be held high to reset TX_Fault.
RS0, RS1 rate select timing for FC	t_RS0_FC, RS1_FC		500	μs	From assertion till stable output.
RS0, RS1 rate select timing non FC	t_RS0, t_RS1		10	ms	From assertion till stable output.

Parameter	Symbol	Min.	Max.	Unit	Conditions
Rx_LOS assert delay	t_los_on		100	μs	From occurrence of loss of signal to assertion of RX_Los.
Rx_LOS negate delay	t_los_off		100	μs	From occurrence of presence of signal to negation of RX_Los.

11. Mechanical Dimensions

Comply with SFF-8432 rev. 5.0, the improved Pluggable form factor specification.

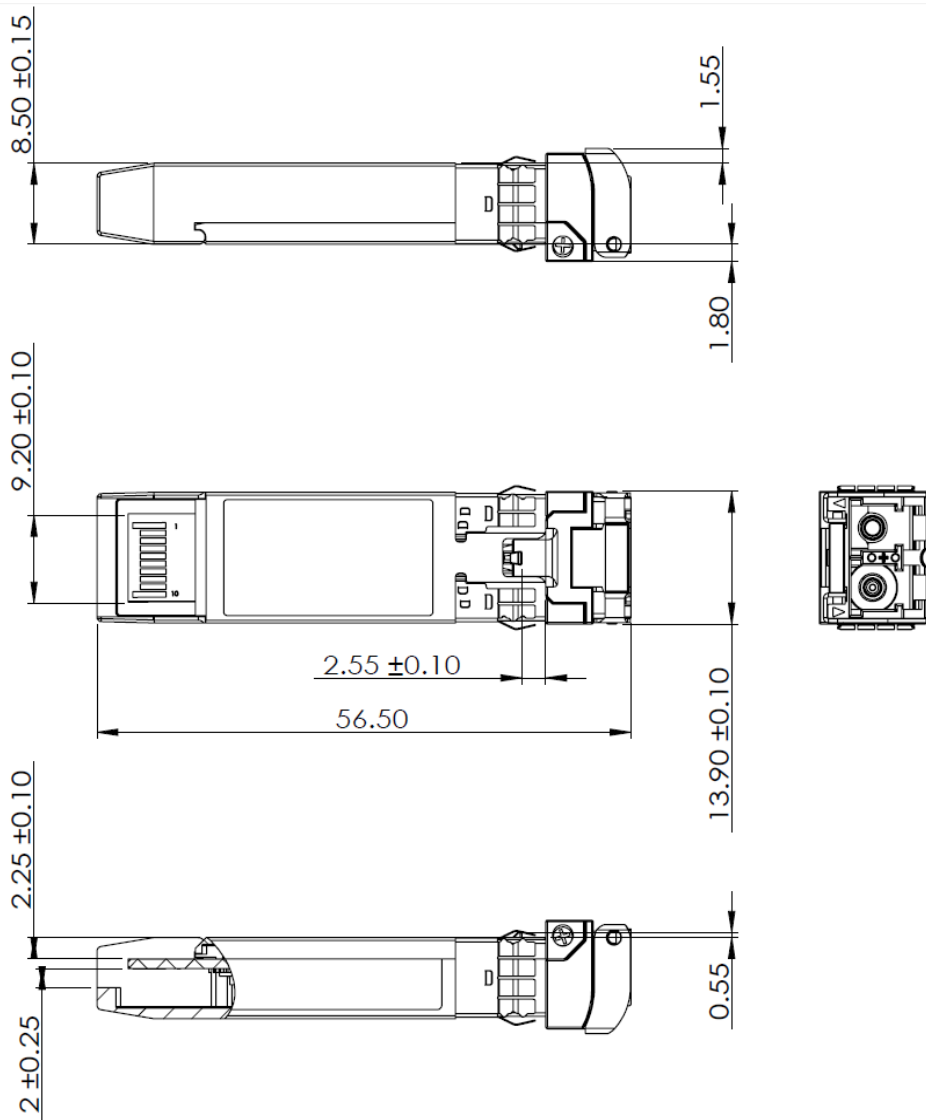

12. ESD

This transceiver is specified as ESD threshold 1kV for SFI pins and 2kv for all others electrical input pins, tested per MIL-STD-883, Method 3015.4 /JESD22-A114-A (HBM). However, normal ESD precautions are still required during the handling of this module. This transceiver is shipped in ESD protective packaging. It should be removed from the packaging and handled only in an ESD protected environment.

13. Laser Safety

This is a Class 1 Laser Product according to IEC 60825-1:2007. This product complies with 21 CFR 1040.10 and 1040.11 except for deviations pursuant to Laser Notice No. 50, dated (June 24, 2007).

14. Ordering information¹

Part Number	Product Description
XTM855-xxLY	25 Gbps 850 nm Multimode SFP28 Transceiver

Notes:

¹ For accurate order specification please contact Xenopt reseller before placing an order. The content of this document is subject to change without notice. Xenopt does not guarantee errorless or outdated information. Please specify any compatibility requirements at time of ordering.

Performance figures, data and any illustrative material provided in this data sheet are typical and must be specifically confirmed in writing by XenOpt before they become applicable to any particular order or contract. In accordance with the XenOpt policy of continuous improvement specifications may change without notice.

The publication of information in this data sheet does not imply freedom from patent or other protective rights of XenOpt or others. Further details are available from any XenOpt sales representative.

To find out more, please contact: