

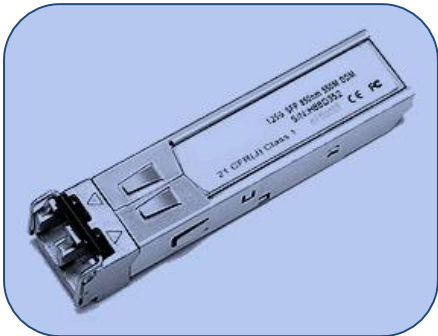

XTM85A-M3LY

10 Gbps SFP+ Optical Transceiver, 300 m Reach, DDM

XTM85A-M3LY 10 Gbps SFP+, 300 m Reach



Applications

- 10GBASE-SR at 10.3125Gbps
- 10GBASE-SW at 9.953Gbps
- Other optical links

Product description

This 850 nm VCSEL 10Gigabit SFP+ transceiver is designed to transmit and receive optical data over 50/125 μm or 62.5/125 μm multimode optical fiber (Table 1).

- Product Highlights**
- Optical interface compliant to IEEE 802.3ae 10GBASE-SR
 - Electrical interface compliant to SFF-8431
 - Hot Pluggable
 - 850 nm VCSEL transmitter, PIN photo-detector
 - Maximum link length of 300 m on 2000 MHz/km MMF
 - Operating case temperature: 0 to 70°C
 - Low power consumption
 - All-metal housing for superior EMI performance
 - Advanced firmware allow customer system encryption information to be stored in transceiver
 - Cost effective SFP+ solution, enables higher port densities and greater bandwidth

Fiber type	Minimum modal bandwidth @ 850 nm (MHz*km)	Operating range (meters)
62,5 μm MMF	160	2 to 26
	200	2 to 33
50 μm MMF	400	2 to 66
	500	2 to 82
	2000	2 to 300

Table 1: SFP+ SR Operating Range for each Optical Fiber Type

The SFP+ SR module electrical interface is compliant to SFI electrical specifications. The transmitter input and receiver output impedance is 100 Ohms differential. Data lines are internally AC coupled. The module provides differential termination and reduce differential to common mode conversion for quality signal termination and low EMI. SFI typically operates over 200 mm of improved FR4 material or up to about 150mm of standard FR4 with one connector.

The transmitter converts 10Gbit/s serial PECL or CML electrical data into serial optical data compliant with the 10GBASE-SR standard. An open collector compatible Transmit Disable (Tx_Dis) is provided. A logic "1," or no connection on this pin will disable the laser from transmitting. A logic "0" on this pin provides normal operation. The transmitter has an internal automatic power control loop (APC) to ensure constant optical power output across supply voltage and temperature variations. An open collector compatible Transmit Fault (TFault) is provided. TX_Fault is module outputs contact that when high, indicates that the module transmitter has detected a fault condition related to laser operation or safety. The TX_Fault output contact is an open drain/collector and shall be pulled up to the Vcc_Host in the host with a resistor in the range 4.7-10 kΩ. TX_Disable is a module input contact. When TX_Disable is asserted high or left open, the SFP+ module transmitter output shall be turned off. This contact shall be pulled up to VccT with a 4.7 kΩ to 10 kΩ resistor.

The receiver converts 10Gbit/s serial optical data into serial PECL/CML electrical data. An open collector compatible Loss of Signal is provided. Rx_LOS when high indicates an optical signal level below that specified in the relevant standard. The Rx_LOS contact is an open drain/collector output and shall be pulled up to Vcc_Host in the host with a resistor in the range 4.7-10 kΩ, or with an active termination. Power supply filtering is recommended for both the transmitter and receiver. The Rx_LOS signal is intended as a preliminary indication to the system in which the SFP+ is installed that the received signal strength is below the specified range. Such an indication typically points to non-installed cables, broken cables, or a disabled, failing or a powered off transmitter at the far end of the cable.

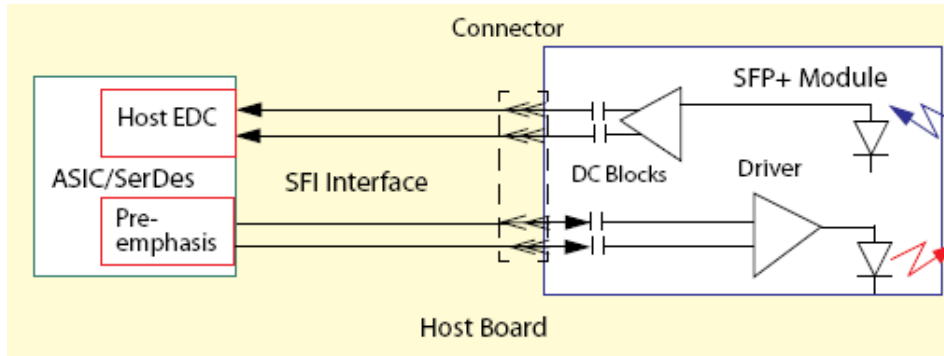

Figure 1: Interface to Host

Pin definition

The SFP+ modules are hot-pluggable. Hot pluggable refers to plugging in or unplugging a module while the host board is powered. The SFP+ host connector is a 0.8 mm pitch 20 position right angle improved connector specified by SFF-8083, or stacked connector with equivalent with equivalent electrical performance. Host PCB contact assignment is shown in Figure 2 and contact definitions are given in Table 2. SFP+ module contacts mates with the host in the order of ground, power, followed by signal as illustrated by Figure 3 and the contact sequence order listed in Table 2.

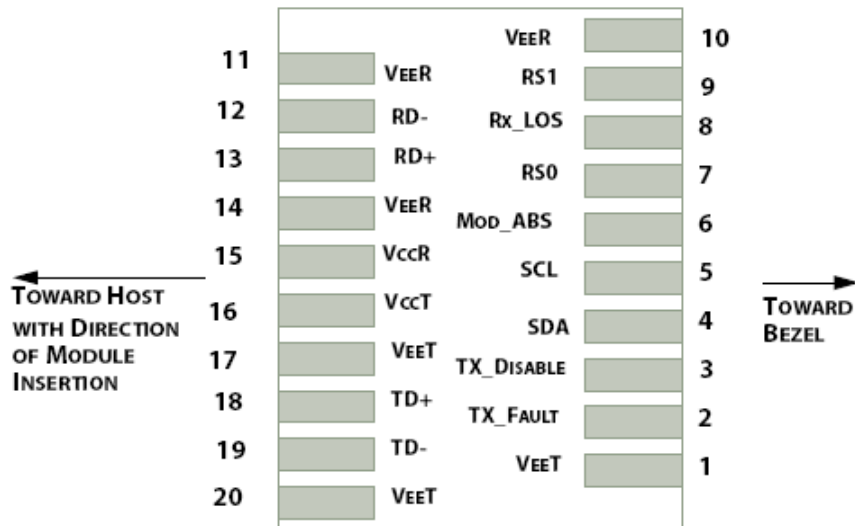

Figure 2: Interface to Host PCB

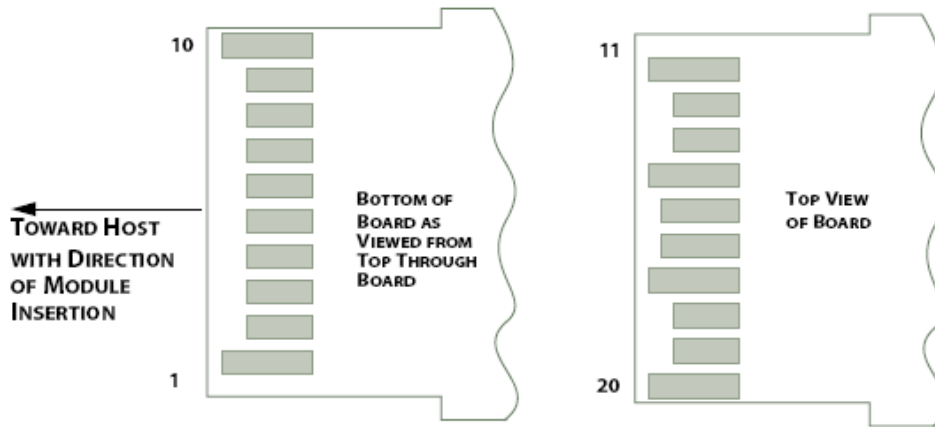

Figure 3: Module Contact Assignment

PIN	Logic	Signal Name	Power Sequence Order	Description
1		VeeT	1 st	Module Transmitter Ground
2	LVTTL-O	TX_Fault	3 rd	Module Transmitter Fault
3	LVTTL-I	TX_Disable	3 rd	Transmitter Disable; Turns off transmitter laser output
4	LVTTL-O	SDA	3 rd	Modulation Definition 2 (INF-8074i) – Two wires serial Interface Data Line
5	LVTTL-O	SDL	3 rd	Modulation Definition 1 (INF-8074i) – Two wires serial Interface Clock Line
6		Mod_ABS	3 rd	Modulation Absent, connected to VeeT or VeeR in the module.
7	LVTTL-I	RS0	3 rd	Rate Select 0: optionally controls SFP+ module receiver. When high output signalling rate > 4,25 GBd and when low input signalling rate ≤ 4,25 GBd
8	LVTTL-O	Rx_LOS	3 rd	Receiver Loss of Signal Indication (In FC designed as Rx_LOS and in Ethernet designed as Signal Detect)
9	LVTTL-I	RS1	3 rd	Rate Select 1: optionally controls SFP+ module transmitter. When high output signalling rate > 4,25 GBd and when low input signalling rate ≤ 4,25 GBd
10		VeeR	1 st	Module Receiver Signal Ground
11		VeeR	1 st	Module Receiver Signal Ground
12	CML-O	RD-	3 rd	Inverse Receiver Data Out
13	CML-O	RD+	3 rd	Receiver Data Out
14		VeeR	1 st	Module Receiver Signal Ground
15		VccR	2 nd	Module Receiver Power – 3.3V±5%
16		VccT	2 nd	Module Transmitter Power – 3.3V±5%
17		VeeT	1 st	Module Transmitter Signal Ground

PIN	Logic	Signal Name	Power Sequence Order	Description
18	CML-I	TD+	3 rd	Transmitter Data Input
19	CML-I	TD-	3 rd	Inverse Transmitter Data Input
20		VeeT	1 st	Transmitter Signal Ground

Table 2: SFP+ Module PIN Definition

Absolute maximum rating

These values represent the damage threshold of the module. Stress in excess of any of the individual Absolute Maximum Ratings can cause immediate catastrophic damage to the module even if all other parameters are within Recommended Operating Conditions.

Parameters	Symbol	Min.	Max.	Unit
Power Supply Voltage	V _{cc}	0	+3,6	V
Storage Temperature	T _c	-40	85	°C
Operating Case Temperature	T _c	-5	75	°C
Operating Relative Humidity	RH	5	95	%
RX Input Average Power	P _{max}	-	0	dBm

Table 3: Absolute Maximum Rating

Recommended operating environment

Recommended Operating Environment specifies parameters for which the electrical and optical characteristics hold unless otherwise noted.

Parameters	Symbol	Min.	Typical	Max.	Unit
Power Supply Voltage	V _{cc}	3.135	3.300	3.465	V
Operating Case Temperature	T _c	0	25	70	°C

Table 4: Recommended Operating Environment

Optical Characteristics

The following optical characteristics are defined over the Recommended Operating Environment unless otherwise specified.

Parameters	Symbol	Min.	Typical	Max.	Unit	Notes
Transmitter						

Center Wavelength	λ_t	840	850	860	nm	
RMS spectral width	Pm	-	-	Note 1	nm	
Average Optical Power	Pavg	-6.5	-	-1	dBm	2
Extinction Ratio	ER	3.5	-	-	dB	3
Transmitter Dispersion Penalty	TDP	-	-	3.9	dB	
Relative Intensity Noise	Rin	-	-	-128	dB/Hz	12dB
Optical Return Loss Tolerance		-	-	12	dB	
Receiver						
Center Wavelength	λ_r	840	850	860	nm	
Receiver Sensitivity	Psens	-	-	-11.1	dBm	4
Stressed Sensitivity in OMA		-	-	-7.5	dBm	4
Los function	Los	-30	-	-12	dBm	
Overload	Pin	-	-	-1.0	dBm	4
Receiver Reflectance		-	-	-12	dB	
Notes:						
1. Trade-offs are available between spectral width, center wavelength and minimum OMA, as shown in table 6.						
2. The optical power is launched into MMF						
3. Measured with a PRBS 231-1 test pattern @10.3125Gbps						
4. Measured with a PRBS 231-1 test pattern @10.3125Gbps, BER≤10-12.						

Table 5: Optical Characteristics

Center Wavelength (nm)	RMS Spectral Width (nm)								
	Up to 0,05	0,05 to 0,1	0,1 to 0,15	0,15 to 0,2	0,2 to 0,25	0,25 to 0,3	0,3 to 0,35	0,35 to 0,4	0,4 to 0,45
840 to 842	-4,2	-4,2	-4,1	-4,1	-3,9	-3,8	-3,5	-3,2	-2,8
842 to 844	-4,2	-4,2	-4,2	-4,1	-3,9	-3,8	-3,6	-3,3	-2,9
844 to 846	-4,2	-4,2	-4,2	-4,1	-4,0	-3,8	-3,6	-3,3	-2,9
846 to 848	-4,3	-4,2	-4,2	-4,1	-4,0	-3,8	-3,6	-3,3	-2,9
848 to 850	-4,3	-4,2	-4,2	-4,1	-4,0	-3,8	-3,6	-3,3	-3,0
850 to 852	-4,3	-4,2	-4,2	-4,1	-4,0	-3,8	-3,6	-3,4	-3,0
852 to 854	-4,3	-4,2	-4,2	-4,1	-4,0	-3,9	-3,7	-3,4	-3,1
854 to 856	-4,3	-4,3	-4,2	-4,1	-4,0	-3,9	-3,7	-3,4	-3,1
856 to 858	-4,3	-4,3	-4,2	-4,1	-4,0	-3,9	-3,7	-3,5	-3,1
858 to 860	-4,3	-4,3	-4,2	-4,2	-4,1	-3,9	-3,7	-3,5	-3,2

Table 6: Minimum 10GBASE-SR OMA as a Function of Wavelength and Spectral Width

Digital Diagnostic Functions

The following digital diagnostic characteristics are defined over the Recommended Operating Environment unless otherwise specified. It is compliant to SFF8472 Rev9.2 with internal calibration mode. For external calibration mode please contact our sales staff.

Parameters	Symbol	Min.	Max.	Unit	Notes
Temperature monitor absolute error	DMI_Temp	-3	+3	degC	Over operating temp
Laser power monitor absolute error	DMI_TX	-3	+3	dB	

RX power monitor absolute error	DMI_RX	-3	+3	dB	-3dBm to -12dBm
Supply voltage monitor absolute error	DMI_VCC	-0.08	+0.08	V	Full operating range
Bias current monitor	DMI_Ibias	-10%	10%	mA	

Electrical characteristics

The following electrical characteristics are defined over the Recommended Operating Environment unless otherwise specified.

Parameters	Symbol	Min.	Typical	Max.	Unit	Notes
Data Rate		-	10.3125	-	Gbps	
Power Consumption		-	600	800	mW	
Transmitter						
Single Ended Output Voltage Tolerance		-0.3	-	4.0	V	
C common mode voltage tolerance		15	-	-	mV	
Tx Input Diff Voltage	VI	180		1200	mV	
Tx Fault	VoL	-0.3		0.4	V	At 0.7mA
Data Dependent Input Jitter	DDJ			0.10	UI	
Data Input Total Jitter	TJ			0.28	UI	
Receiver						
Single Ended Output Voltage Tolerance		-0.3	-	4.0	V	
Rx Output Diff Voltage	Vo	300		850	mV	
Rx Output Rise and Fall Time	Tr/Tf	30			ps	20% to 80%
Total Jitter	TJ			0.70	UI	
Deterministic Jitter	DJ			0.42	UI	

Table 7: Electrical Characteristics

Control and status I/O timing characteristics

Timing characteristics of control and status I/O are included in Table 8, which is also defined in SFF-8431.

Parameter	Symbol	Min.	Max.	Unit	Conditions
TX_Disable assert time	t_off		100	μs	Rising edge of TX_Disable to fall of output signal below 10% of normal
TX_Disable negate time	t_on		2	ms	Falling edge of TX_Disable to rise of output signal above 90% of normal operation, not during start up of fault recovery.
Time to initialize 2-wire interface	t_2w_start_up		300	ms	From power on or hot plug meeting mechanical dimensions

Parameter	Symbol	Min.	Max.	Unit	Conditions
Time to initialize	t_start_up		300	ms	From power supply meeting mechanical dimensions or hot plug, or Tx_disable negated power up or Tx_Fault recovery, until non-cooled power level I part (or non-cooled power level II part already enabled at power level II for Tx_Fault recovery) is fully operational.
Time to initialize cooled module	t_start_up_cooled		90	s	From power supply meeting mechanical dimensions or hot plug, or Tx_disable negated power up or Tx_Fault recovery, until non-cooled power level I part (or cooled power level II part part during fault recovery) is fully operational.
Time to Power Up to Level II	t_power_lev2		300	ms	From falling edge of stop bit enabling power level II until non-cooled module is fully operational.
Time to Power Down from Level II	t_power_down		300	ms	From falling edge of stop bit disabling power level II until within power level I requirements.
TX_Fault assert	TX_Fault_on		1	ms	From occurrence of fault to assertion of TX_Fault.
TX_Fault assert for cooled module	TX_Fault_on_cooled		50	ms	From occurrence of fault to assertion of TX_Fault.
TX_Fault Reset	t_reset	10		μs	Time TX_Disable must be held high to reset TX_Fault.
RS0, RS1 rate select timing for FC	t_RS0_FC, RS1_FC		500	μs	From assertion till stable output.
RS0, RS1 rate select timing non FC	t_RS0, t_RS1		10	ms	From assertion till stable output.
Rx_LOS assert delay	t_los_on		100	μs	From occurrence of loss of signal to assertion of RX_Los.
Rx_LOS negate delay	t_los_off		100	μs	From occurrence of presence of signal to negation of RX_Los.

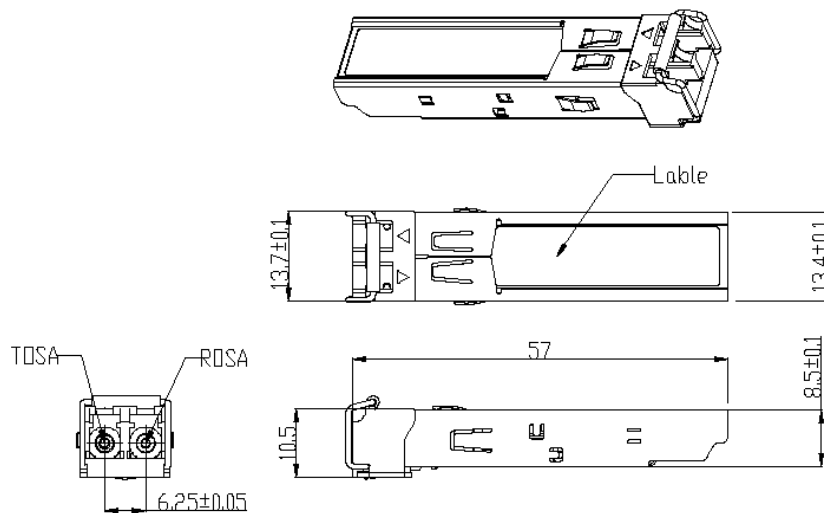
Mechanical**Table 9: Key Mechanical Dimensions****ESD**

This transceiver is specified as ESD threshold 2kV for all electrical input pins, tested per MIL-STD-883, Method 3015.4 /JESD22-A114-A (HBM). However, normal ESD precautions are still required during the handling of this module. This transceiver is shipped in ESD protective packaging. It should be removed from the packaging and handled only in an ESD protected environment.

LASER SAFTY

This is a Class 1 Laser Product according to IEC 60825-1:1993+A1:1997+A2:2001. This product complies with 21 CFR 1040.10 and 1040.11 except for deviations pursuant to Laser Notice No. 50, dated (July 26, 2001).

Ordering information

Part Number	Product Description
XTM85A-M3LY	850 nm, 10 Gbps, 300 m, LC, 0°C ~ +70°C, Digital Diagnostic Monitoring

Important Notice

Performance figures, data and any illustrative material provided in this data sheet are typical and must be specifically confirmed in writing by XenOpt before they become applicable to any particular order or contract. In accordance with the XenOpt policy of continuous improvement specifications may change without notice.

The publication of information in this data sheet does not imply freedom from patent or other protective rights of XenOpt or others. Further details are available from any XenOpt sales representative.

To find out more, please contact:

XenOpt