

XTS315-20LY

SFP28 25 Gbps, 20 km Reach
Single Mode Transceiver



Features

- Supports up to 25.78 Gbps bit rates
- Hot-pluggable SFP+ footprint
- 1310 nm DFB laser and PIN photodiode
- Up to 20 km for SMF transmission
- Compliant with SFP+ MSA and SFF-8472
- Duplex LC receptacle
- Real Time Digital Diagnostic Monitoring
- Single +3.3 V power supply
- Operating Case Temperature Range 0°C to +70°C
- RoHS compliant

Applications

- 25GBASE-LR

Description

The SFP28 transceivers are efficient, cost-effective modules supporting a data rate of 25.78 Gbps and a transmission distance of up to 20 km using single-mode fiber (SMF). They comprise a DFB laser transmitter, a PIN photodiode with a trans-impedance preamplifier (TIA), and an MCU control unit. These modules adhere to class I laser safety standards and are compliant with the SFP Multi-Source Agreement and SFF-8472 digital diagnostics functions.

Block Diagram

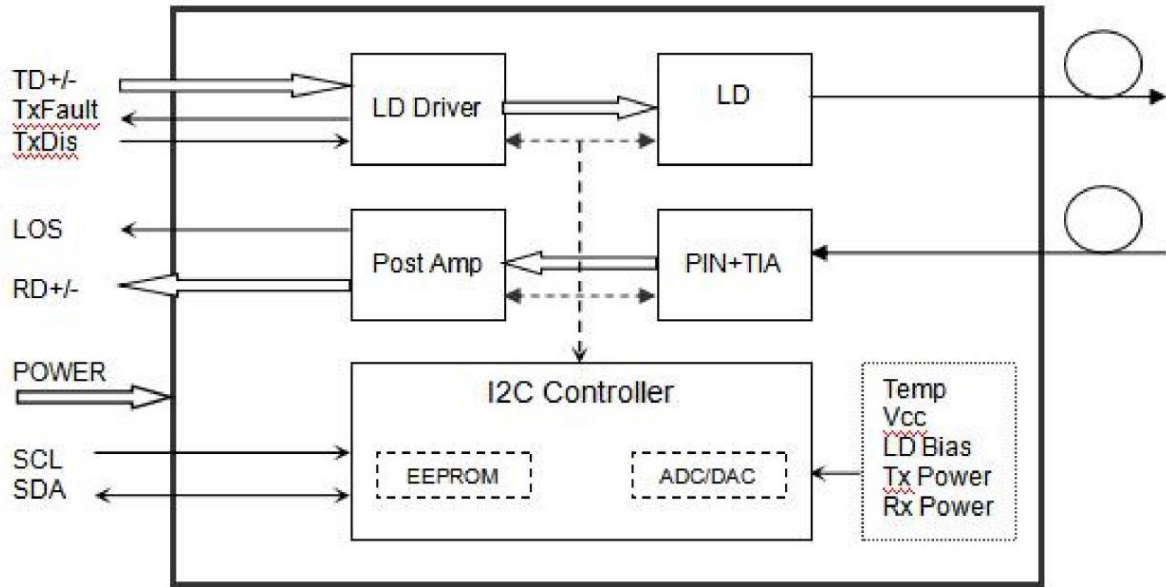

Absolute Maximum Ratings

Parameter	Symbol	Min	Max	Unit
Supply Voltage	Vcc	-0.5	4.5	V
Storage Temperature	Ts	-40	+85	°C
Operating Humidity	-	5	85	%

Recommended Operating Conditions

Parameter	Symbol	Min	Typical	Max	Unit
Operating Case Temperature	Tc	0		+70	°C
Power Supply Voltage	Vcc	3.135	3.30	3.465	V
Power Supply Current	Icc			400	mA
Data Rate			25.78		Gbps

Optical and Electrical Characteristics

Parameter	Symbol	Min	Typical	Max	Unit	Notes
Transmitter						
Centre Wavelength	λ_c	1270	1310	1350	nm	
Spectral Width (-20dB)	$\Delta\lambda$			1	nm	
Side-Mode Suppression Ratio	SMSR	30	-		dB	
Average Output Power	P_{out}	-6		+2	dBm	1
Extinction Ratio	ER	3.5			dB	
Data Input Swing Differential	V_{IN}	180		850	mV	2
Input Differential Impedance	Z_{IN}	90	100	110	Ω	
TX Disable	Disable		2.0		Vcc	V
	Enable		0		0.8	V
TX Fault	Fault		2.0		Vcc	V
	Normal		0		0.8	V
Receiver						
Centre Wavelength	λ_c	1260		1600	nm	
Receiver Sensitivity				-13.3	dBm	3
Receiver Overload				2	dBm	3
LOS De-Assert	LOS_D			-15	dBm	
LOS Assert	LOS_A	-30			dBm	
LOS Hysteresis		0.5			dB	
Data Output Swing Differential	V_{out}	300		900	mV	4
LOS	High	2.0		Vcc	V	
	Low			0.8	V	

Notes

1. The optical power is launched into SMF.
2. PECL input, internally AC-coupled and terminated.
3. Measured with a PRBS $2^{31}-1$ test pattern @25.78 Gbps, BER $\leq 5 \times 10^{-5}$.
4. Internally AC-coupled.

Ordering information²

Part number	Product Description
XTS315-20LY	SFP28 SMF, 1310 nm, 25.78 Gbps, 20 km, LC, 0°C~+70°C, DDM

Notes

¹ For the latest certification information, please check with Xenopt

² For accurate order specification please contact XenOpt reseller before placing an order. The content of this document is subject to change without notice. XenOpt does not guarantee errorless or outdated information.

Please specify any compatibility requirements at time of ordering. Standard MSA compatible pluggable components may not work or some function of these components may not be available in devices that require customized compatible devices. Pluggable components compatible with one type of communications equipment may not work in other type of communications equipment.

Important Notice

Performance figures, data and any illustrative material provided in this data sheet are typical and must be specifically confirmed in writing by XenOpt before they become applicable to any particular order or contract. In accordance with the XenOpt policy of continuous improvement specifications may change without notice.

The product image is only for reference purpose

The publication of information in this data sheet does not imply freedom from patent or other protective rights of XenOpt or others. Further details are available from any XenOpt sales representative.

To find out more, please contact: