

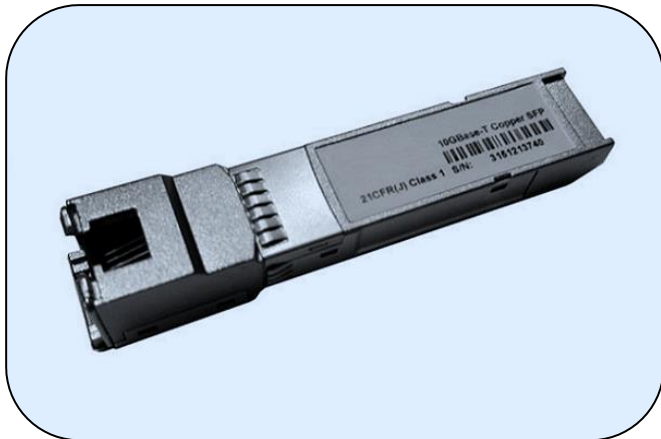

# XTUEDA-B3RN

## 10 Gbps BASE-T SFP+ Transceiver

XTUEDA-B3RN



### Applications

- Switch to Switch interface
- Switched backplane applications
- 10G BASE-T operation in host systems with SFI interface

### Description

XTUEDA-B3RN according to 10G BASE-T Copper Small Form Factor Pluggable (SFP+) transceivers are based on the SFP Multi Source Agreement (MSA). They are compatible with the IEEE Std 802.3™ 2008 and SFF-8431 and SFF-8432.

XTUEDA-B3RN are compliant with RoHS.

### Features

- Compliant with SFP+ MSA
- Up to 10.3125 Gbps bi-directional data links
- SFP form with compact RJ-45 connector
- +3.3 V single power supply
- Hot-pluggable
- 30 meters over Cat 6a/7
- Operating case temperature  
Commercial: 0°C to +70°C
- Auto-Negotiation per IEEE 802.3™ 2008
- Access to physical layer IC via 2-wire serial bus
- RoHS compliant and Lead Free

## Absolute Maximum Ratings

Stresses in excess of the absolute maximum ratings can cause permanent damage to the device. These are absolute stress ratings only. Functional operation of the device is not implied at these or any other conditions in excess of those given in the operational sections of the data sheet. Exposure to absolute maximum ratings for extended periods can adversely affect device reliability.

Table 1 Absolute Maximum Ratings

Parameter	Symbol	Minimum	Maximum	Unit
Storage Temperature	$T_s$	-40	85	°C
Relative Humidity	RH	5	95	%
Supply Voltage	$V_{CC}$	-0.5	4.0	V

## Recommended Operating Conditions

Table 2 Recommended Operating Conditions

Parameter	Symbol	Minimum	Typical	Maximum	Unit
Operating Case Temperature	$T_c$	0	25	70	°C
Supply Voltage	$V_{CC}$	3.135	3.3	3.465	V
Data Rate	-	-	10.3125	-	Gb/s

## Transceiver Electrical Characteristics

Table 3 Transceiver Electrical Characteristics

Parameter	Symbol	Minimum	Typical	Maximum	Unit	Notes
Module Supply Current	$I_{CC}$	-	-	910	mA	-
Total Power Consumption	PD	-	2.5	3.0	W	
Differential Input Swing	$V_{IN}$	180	-	700	mV <sub>p,p</sub>	1
Differential Output Swing	$V_O$	300	-	850	mV <sub>p,p</sub>	2
Differential Input Impedance	ZTX	80	100	120	Ω	
Rise/Fall Time	$T_r, T_f$	20			ps	
Bit Error Ratio	BER			$10^{-12}$		
Low speed input: Transmitter Disable (TX_DISABLE), SDA, SCL	$V_{IH}$	2.0	-	$V_{CC}$	V	3
	$V_{IL}$	0	-	0.8	V	-

### Notes

- Internally AC coupled and terminated to 100 Ω differential load.
- Internally AC coupled, but requires a 100 Ω differential termination or internal to Serializer/Deserializer.
- SDA and SCL must be pulled up externally with a 4.7 KΩ -10 KΩ resistor on the host board to  $V_{CC,T,R}$ .

## PIN Description

Table 4 PIN Description

Pin	Name	Function/Description	Engagement order (Insertion)	Notes
1	VeeT	Transmitter Ground	1	-
2	TX Fault	Transmitter Fault Indication Grounded in the module	3	
3	TX Disable	PHY Reset-PHY Reset on high or open	3	1
4	SDA	Module Definition 2-Two wire serial ID interface	3	2
5	SCL	Module Definition 1-Two wire serial ID interface	3	2
6	MOD-ABS	Module Definition 0-Grounded in module	3	2
7	RS0	Rate Select 0	3	-
8	LOS	Loss of Signal	3	3
9	RS1	Rate Select 1	1	-
10	VeeR	Receiver Ground	1	-
11	VeeR	Receiver Ground	1	-
12	RD-	Inverse Received Data out	3	4
13	RD+	Received Data out	3	4
14	VeeR	Receiver Ground	1	-
15	VccR	Receiver Power - +3.3V± 5%	2	5
16	VccT	Transmitter Power - +3.3 V± 5%	2	5
17	VeeT	Transmitter Ground	1	-
18	TD+	Transmitter Data In	3	6
19	TD-	Inverse Transmitter Data In	3	6
20	VeeT	Transmitter Ground	1	-

### Notes:

- TX Disable input is used to shut down the PHY. It is pulled up within the module with a 4.7 – 10 K resistor.  
 Low (0 – 0.8V): PHY Enabled  
 Between (0.8V and 2V): Undefined  
 High (2.0 – VccT): PHY Disabled  
 Open : PHY Disabled
- Mod-ABS, SDA, SCL. These are the module definition pins. They should be pulled up with a 4.7 KΩ-10 KΩ resistor on the host board to supply less than VccT+0.5 V or VccR+0.5 V.  
 Mod-ABS is grounded by the module to indicate that the module is present.  
 SDA is clock line of two wire serial interface for optional serial ID.  
 SCL is data line of two wire serial interface for optional serial ID.
- LOS is Grounded in the module
- RD-/+: These are the differential receiver outputs. They are AC coupled 100 Ω differential lines which should be terminated with 100 Ω differential at the user SERDES. The AC coupling is done inside the module and thus not required on the host board.
- VccRand VccT are the receiver and transmitter power supplies. They are defined as 3.3 V± 5% at the SFP connector pin. The in-rush current will typically be no more than 30 mA above steady state supply current after 500 ns.
- TD-/+: These are the differential transmitter inputs. They are AC coupled differential lines with 100Ω

differential termination inside the module. The AC coupling is done inside the module and is thus not required on host board.

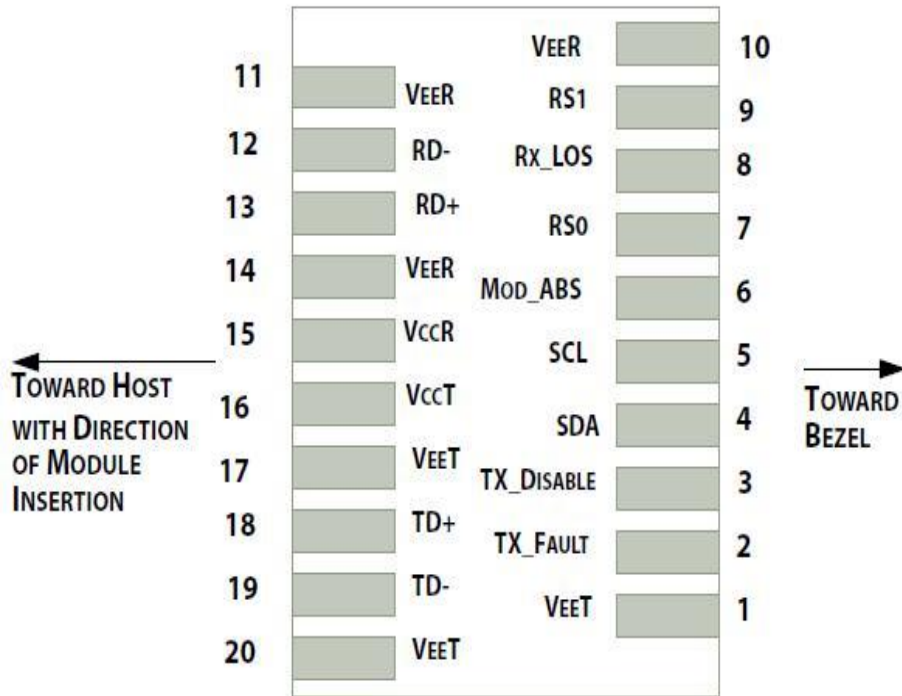

Figure 1 Diagram of Host Board Connector Block Pin Numbers and Names

### EEPROM Serial ID Memory Contents:

The transceiver provides standard serial ID information compatible with SFP MSA, which can be accessed with address of A0h.

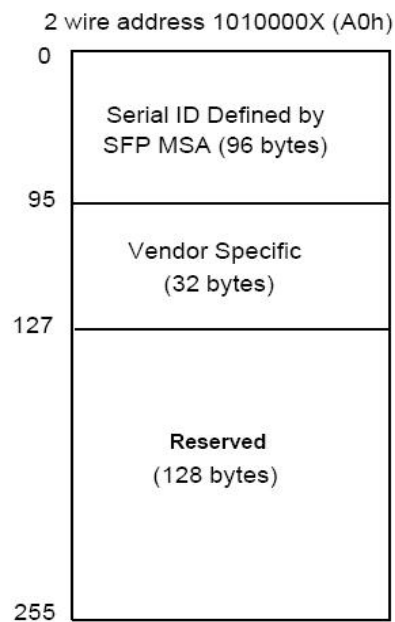

Figure 2 1010000x (A0h) Serial ID Memory Contents

The SFP MSA defines a 256-byte memory map in EEPROM describing the transceiver's capabilities, standard interfaces, manufacturer, and other information, which is accessible over a 2 wire serial interface at the 8-bit address 1010000X (A0h), and the clock frequency up to 100KHz. The memory contents are shown in Table 5.

Table 5 Serial ID Memory Contents

Data Address	Name of the Field	Contents (Hex)	Description
0	Identifier	03	SFP
1	Ext. Identifier	04	SFP function is defined by serial ID
2	Connector	03	SFP/SFP+/SFP28
3-10	Transceiver	00 00 00 00 00 00 00 00	Transceiver Codes
11	Encoding	06	64B66B
12	BR, Nominal	67	10.3 Gb/s
13	Reserved	00	
14	Length (9 μm) km	00	
15	Length (9 μm) 100 m	00	
16	Length (50 μm) 10 m	00	
17	Length (62.5 μm) 10 m	00	
18	Length (Copper)	1E	30 m@ category 6a/7 UTP

19	Reserved	00	
20-35	Vendor name	4C 49 4E 4B 54 45 46 20 20 20 20 20 20 20 20 20	"XENOPT" (ASCII)
36	Reserved	16	10GBASE-T
37-39	Vendor OUI	00 00 00	
40-55	Vendor PN	4C 58 34 30 30 36 43 4E 52 20 20 20 20 20 20 20	"XTUEDA-B3RN" (ASCII)
56-59	Vendor rev	31 2E 30 20	Rev 1.0 ( ASCII)
60-61	Wavelength	00 00	-
62	Reserved	00	
63	CC BASE	xx	Check sum of bytes 0 - 62
64-65	Options	00 10	TX_DISABLE - Reset-PHY on high or open
66	BR, max	00	
67	BR, min	00	
68-83	Vendor SN	xx xx xx xx xx xx xx xx xx xx xx xx xx xx xx xx	ASCII
84-91	Vendor date code	xx xx xx xx xx xx 20 20	Year (2 bytes), Month (2 bytes), Day (2 bytes)
92	Diagnostic type	00	
93	Enhanced option	00	
94	SFF-8472	00	
95	CC_EXT	xx	Check sum for bytes 64-94
96-255		00	

Note: The "xx" byte should be filled in according to practical case.

### Required Host Board Components

The MSA power supply noise rejection filter is required on the host PCB to meet data sheet performance. The MSA filter incorporates an inductor which should be rated 400 mA DC and 1  $\Omega$  serial resistance or better. It should not be replaced with a ferrite. The required filter is illustrated in Figure 3. The MSA also specifies that 4.7 K $\Omega$  to 10 K $\Omega$  pull-up resistors for TX\_FAULT, LOS, and MOD\_DEF0, 1, 2 are required on the host PCB. Figure is the suggested transceiver/host interface. Figure 3 shows the recommended host board power supply circuit

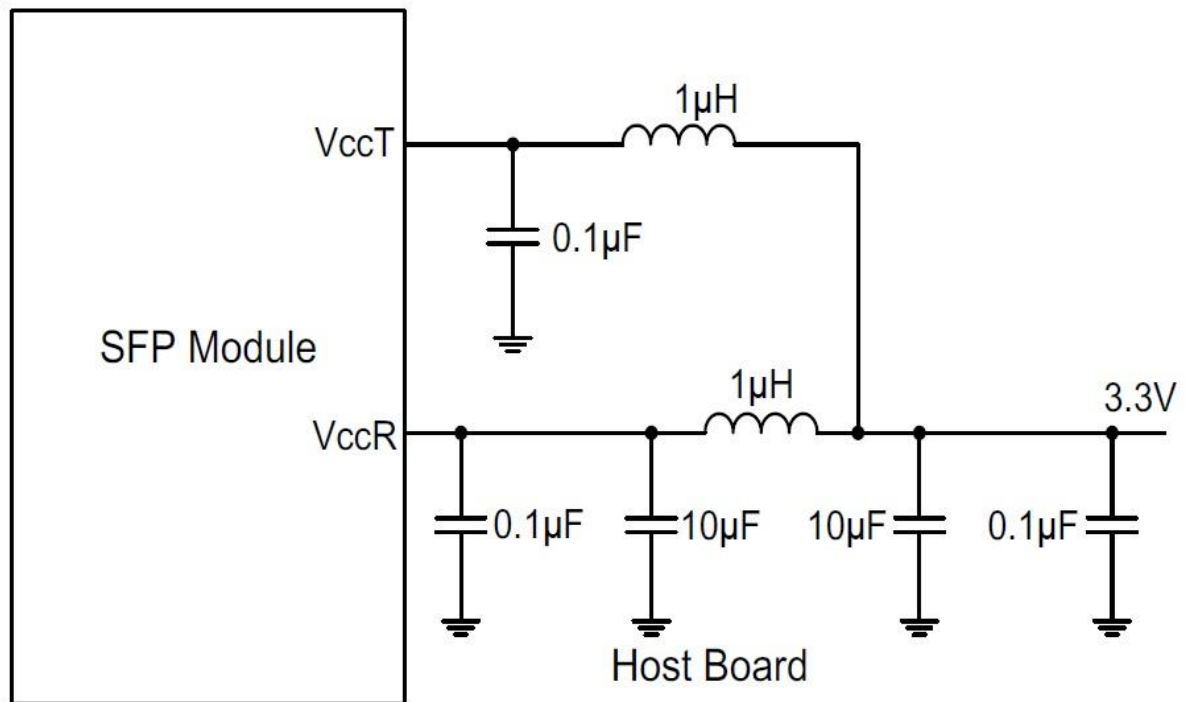

Figure 3 Recommended Host Board Power Supply Circuit

PCB layout recommendation

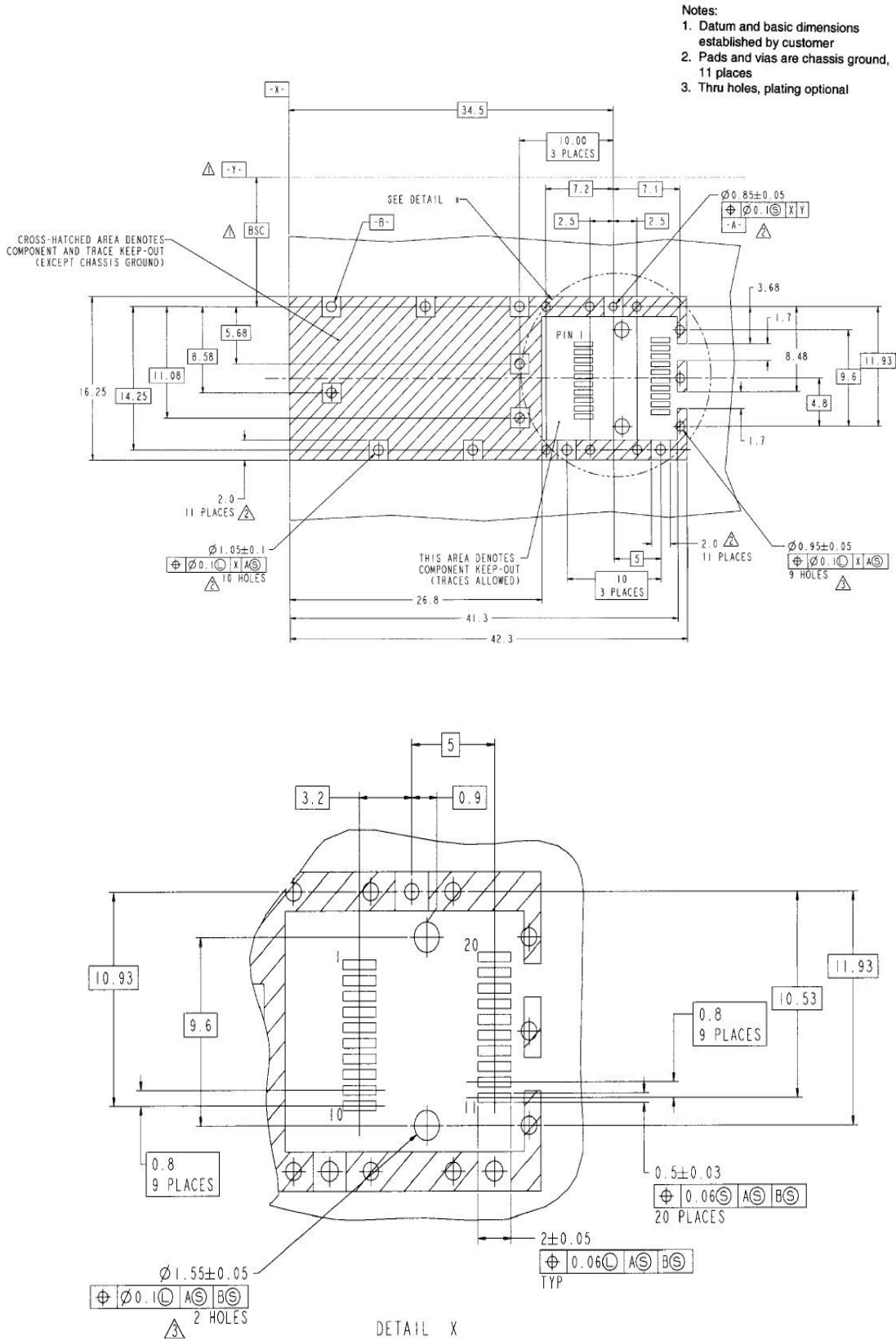

Figure 4 PCB layout recommendation



**Mechanical specifications**

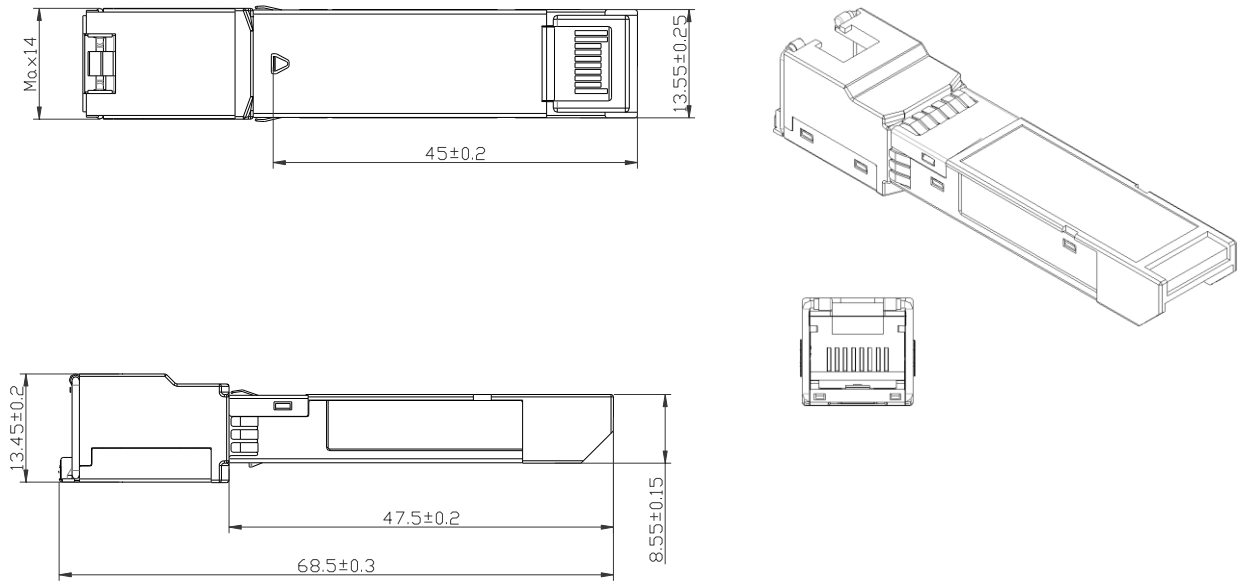

Figure 5 Outline Drawing

## Ordering information<sup>1</sup>

PN	Description
XTUEDA-B3RN	SFP+, copper, 10.3125 Gb Eth, 30 m, RJ-45, 0°C to +70°C, SFI, auto-negotiation

### Notes:

<sup>1</sup> For accurate order specification please contact XenOpt reseller before placing an order. The content of this document is subject to change without notice.

Please specify any host device compatibility requirements at the time of ordering. Standard MSA compatible pluggable components may not work, or some function of these components may not be available in devices that require customized pluggable devices. Pluggable components that are compatible with one type of communications equipment may not work in other type of communications equipment.

### Important Notice

Performance figures, data and any illustrative material provided in this data sheet are contains typical values and must be specifically confirmed in writing by XenOpt before they become applicable to any particular order or contract. Specifications may change without notice

The publication of information in this data sheet does not imply freedom from of patent or other protective rights of XenOpt or others. Further details are available from any XenOpt sales representative.

To find out more, please contact: